

KEITHLEY

Model 2002 Multimeter Calibration Manual

A GREATER MEASURE OF CONFIDENCE

WARRANTY

Keithley Instruments, Inc. warrants this product to be free from defects in material and workmanship for a period of 3 years from date of shipment.

Keithley Instruments, Inc. warrants the following items for 90 days from the date of shipment: probes, cables, rechargeable batteries, diskettes, and documentation.

During the warranty period, we will, at our option, either repair or replace any product that proves to be defective.

To exercise this warranty, write or call your local Keithley representative, or contact Keithley headquarters in Cleveland, Ohio. You will be given prompt assistance and return instructions. Send the product, transportation prepaid, to the indicated service facility. Repairs will be made and the product returned, transportation prepaid. Repaired or replaced products are warranted for the balance of the original warranty period, or at least 90 days.

LIMITATION OF WARRANTY

This warranty does not apply to defects resulting from product modification without Keithley's express written consent, or misuse of any product or part. This warranty also does not apply to fuses, software, non-rechargeable batteries, damage from battery leakage, or problems arising from normal wear or failure to follow instructions.

THIS WARRANTY IS IN LIEU OF ALL OTHER WARRANTIES, EXPRESSED OR IMPLIED, INCLUDING ANY IMPLIED WARRANTY OF MERCHANTABILITY OR FITNESS FOR A PARTICULAR USE. THE REMEDIES PROVIDED HEREIN ARE BUYER'S SOLE AND EXCLUSIVE REMEDIES.

NEITHER KEITHLEY INSTRUMENTS, INC. NOR ANY OF ITS EMPLOYEES SHALL BE LIABLE FOR ANY DIRECT, INDIRECT, SPECIAL, INCIDENTAL OR CONSEQUENTIAL DAMAGES ARISING OUT OF THE USE OF ITS INSTRUMENTS AND SOFTWARE EVEN IF KEITHLEY INSTRUMENTS, INC., HAS BEEN ADVISED IN ADVANCE OF THE POSSIBILITY OF SUCH DAMAGES. SUCH EXCLUDED DAMAGES SHALL INCLUDE, BUT ARE NOT LIMITED TO: COSTS OF REMOVAL AND INSTALLATION, LOSSES SUSTAINED AS THE RESULT OF INJURY TO ANY PERSON, OR DAMAGE TO PROPERTY.



A G R E A T E R M E A S U R E O F C O N F I D E N C E

Keithley Instruments, Inc.

Corporate Headquarters • 28775 Aurora Road • Cleveland, Ohio 44139 • 440-248-0400 • Fax: 440-248-6168 • 1-888-KEITHLEY (534-8453) • www.keithley.com

Belgium: Sint-Pieters-Leeuw • 02-363 00 40 • Fax: 02-363 00 64 • www.keithley.nl

China: Beijing • 8610-82251886 • Fax: 8610-82251892 • www.keithley.com.cn

Finland: Helsinki • 09-5306-6560 • Fax: 09-5306-6565 • www.keithley.com

France: Saint-Aubin • 01-64 53 20 20 • Fax: 01-60 11 77 26 • www.keithley.fr

Germany: Germering • 089/84 93 07-40 • Fax: 089/84 93 07-34 • www.keithley.de

Great Britain: Theale • 0118 929 7500 • Fax: 0118 929 7519 • www.keithley.co.uk

India: Bangalore • 91-80 2212 8027 • Fax: 91-80 2212 8005 • www.keithley.com

Italy: Milano • 02-48 39 16 01 • Fax: 02- 48 39 16 28 • www.keithley.it

Japan: Tokyo • 81-3-5733-7555 • Fax: 81-3-5733-7556 • www.keithley.jp

Korea: Seoul • 82-2-574-7778 • Fax: 82-2-574-7838 • www.keithley.com

Netherlands: Gorinchem • 0183-635333 • Fax: 0183-630821 • www.keithley.nl

Singapore: Singapore • 65-6747-9077 • Fax: 65-6747-2991 • www.keithley.com

Sweden: Solna • 08-509 04 600 • Fax: 08-655 26 10 • www.keithley.com

Taiwan: Hsinchu • 886-3-572-9077 • Fax: 886-3-572-9031 • www.keithley.com.tw

Model 2002 Multimeter Calibration Manual

©1994, Keithley Instruments, Inc.
All rights reserved.
Cleveland, Ohio, U.S.A.
Fourth Printing, May 2004
Document Number: 2002-905-01 Rev. D

Manual Print History

The print history shown below lists the printing dates of all Revisions and Addenda created for this manual. The Revision Level letter increases alphabetically as the manual undergoes subsequent updates. Addenda, which are released between Revisions, contain important change information that the user should incorporate immediately into the manual. Addenda are numbered sequentially. When a new Revision is created, all Addenda associated with the previous Revision of the manual are incorporated into the new Revision of the manual. Each new Revision includes a revised copy of this print history page.

Revision A (Document Number 2002-905-01)	April 1994
Addendum A(Document Number 2002-905-02).....	October 1995
Addendum A(Document Number 2002-905-03).....	July 1996
Revision B (Document Number 2002-905-01)	June 1998
Revision C (Document Number 2002-905-01)	November 2000
Revision D (Document Number 2002-905-01)	May 2004

The following safety precautions should be observed before using this product and any associated instrumentation. Although some instruments and accessories would normally be used with non-hazardous voltages, there are situations where hazardous conditions may be present.

This product is intended for use by qualified personnel who recognize shock hazards and are familiar with the safety precautions required to avoid possible injury. Read and follow all installation, operation, and maintenance information carefully before using the product. Refer to the manual for complete product specifications.

If the product is used in a manner not specified, the protection provided by the product may be impaired.

The types of product users are:

Responsible body is the individual or group responsible for the use and maintenance of equipment, for ensuring that the equipment is operated within its specifications and operating limits, and for ensuring that operators are adequately trained.

Operators use the product for its intended function. They must be trained in electrical safety procedures and proper use of the instrument. They must be protected from electric shock and contact with hazardous live circuits.

Maintenance personnel perform routine procedures on the product to keep it operating properly, for example, setting the line voltage or replacing consumable materials. Maintenance procedures are described in the manual. The procedures explicitly state if the operator may perform them. Otherwise, they should be performed only by service personnel.

Service personnel are trained to work on live circuits, and perform safe installations and repairs of products. Only properly trained service personnel may perform installation and service procedures.

Keithley products are designed for use with electrical signals that are rated Measurement Category I and Measurement Category II, as described in the International Electrotechnical Commission (IEC) Standard IEC 60664. Most measurement, control, and data I/O signals are Measurement Category I and must not be directly connected to mains voltage or to voltage sources with high transient over-voltages. Measurement Category II connections require protection for high transient over-voltages often associated with local AC mains connections. Assume all measurement, control, and data I/O connections are for connection to Category I sources unless otherwise marked or described in the Manual.

Exercise extreme caution when a shock hazard is present. Lethal voltage may be present on cable connector jacks or test fixtures. The American National Standards Institute (ANSI) states that a shock hazard exists when voltage levels greater than 30V RMS, 42.4V peak, or 60VDC are present. **A good safety practice is to expect that hazardous voltage is present in any unknown circuit before measuring.**

Operators of this product must be protected from electric shock at all times. The responsible body must ensure that operators are prevented access and/or insulated from every connection point. In some cases, connections must be exposed to potential human contact. Product operators in these circumstances must be trained to protect themselves from the risk of electric shock. If the circuit is capable of operating at or above 1000 volts, **no conductive part of the circuit may be exposed.**

Do not connect switching cards directly to unlimited power circuits. They are intended to be used with impedance limited sources. NEVER connect switching cards directly to AC mains. When connecting sources to switching cards, install protective devices to limit fault current and voltage to the card.

Before operating an instrument, make sure the line cord is connected to a properly grounded power receptacle. Inspect the connecting cables, test leads, and jumpers for possible wear, cracks, or breaks before each use.

When installing equipment where access to the main power cord is restricted, such as rack mounting, a separate main input power disconnect device must be provided, in close proximity to the equipment and within easy reach of the operator.

For maximum safety, do not touch the product, test cables, or any other instruments while power is applied to the circuit under test. ALWAYS remove power from the entire test system and discharge any capacitors before: connecting or disconnecting cables or jumpers, installing or removing switching cards, or making internal changes, such as installing or removing jumpers.

Do not touch any object that could provide a current path to the common side of the circuit under test or power line (earth) ground. Always make measurements with dry hands while standing on a dry, insulated surface capable of withstanding the voltage being measured.

The instrument and accessories must be used in accordance with its specifications and operating instructions or the safety of the equipment may be impaired.

Do not exceed the maximum signal levels of the instruments and accessories, as defined in the specifications and operating information, and as shown on the instrument or test fixture panels, or switching card.

When fuses are used in a product, replace with same type and rating for continued protection against fire hazard.

Chassis connections must only be used as shield connections for measuring circuits, NOT as safety earth ground connections.

If you are using a test fixture, keep the lid closed while power is applied to the device under test. Safe operation requires the use of a lid interlock.

If a  screw is present, connect it to safety earth ground using the wire recommended in the user documentation.

The  symbol on an instrument indicates that the user should refer to the operating instructions located in the manual.

The  symbol on an instrument shows that it can source or measure 1000 volts or more, including the combined effect of normal and common mode voltages. Use standard safety precautions to avoid personal contact with these voltages.

The  symbol indicates a connection terminal to the equipment frame.

The **WARNING** heading in a manual explains dangers that might result in personal injury or death. Always read the associated information very carefully before performing the indicated procedure.

The **CAUTION** heading in a manual explains hazards that could damage the instrument. Such damage may invalidate the warranty.

Instrumentation and accessories shall not be connected to humans.

Before performing any maintenance, disconnect the line cord and all test cables.

To maintain protection from electric shock and fire, replacement components in mains circuits, including the power transformer, test leads, and input jacks, must be purchased from Keithley Instruments. Standard fuses, with applicable national safety approvals, may be used if the rating and type are the same. Other components that are not safety related may be purchased from other suppliers as long as they are equivalent to the original component. (Note that selected parts should be purchased only through Keithley Instruments to maintain accuracy and functionality of the product.) If you are unsure about the applicability of a replacement component, call a Keithley Instruments office for information.

To clean an instrument, use a damp cloth or mild, water based cleaner. Clean the exterior of the instrument only. Do not apply cleaner directly to the instrument or allow liquids to enter or spill on the instrument. Products that consist of a circuit board with no case or chassis (e.g., data acquisition board for installation into a computer) should never require cleaning if handled according to instructions. If the board becomes contaminated and operation is affected, the board should be returned to the factory for proper cleaning/servicing.

Table of Contents

1 Performance Verification

1.1	Introduction	1-1
1.2	Environmental conditions	1-1
1.3	Warm-up period	1-1
1.4	Line power	1-2
1.5	Recommended test equipment	1-2
1.6	Verification limits	1-2
1.6.1	Reading limit calculation example.....	1-2
1.6.2	Additional derating factors.....	1-2
1.7	Restoring default conditions	1-2
1.8	Verification procedures	1-4
1.8.1	DC volts verification	1-4
1.8.2	AC volts verification	1-6
1.8.3	DC current verification	1-11
1.8.4	AC current verification	1-12
1.8.5	Resistance verification	1-13
1.8.6	Frequency accuracy verification	1-15
1.8.7	Temperature reading checks	1-17

2 Calibration

2.1	Introduction	2-1
2.2	Environmental conditions	2-2
2.3	Warm-up period	2-2
2.4	Line power	2-2
2.5	Calibration lock	2-2
2.5.1	Comprehensive calibration lock.....	2-2
2.5.2	Low-level calibration lock	2-2
2.5.3	IEEE-488 bus calibration lock status	2-2
2.6	IEEE-488 bus calibration commands.....	2-2
2.7	Calibration errors	2-4
2.7.1	Front panel error reporting	2-4
2.7.2	IEEE-488 bus error reporting.....	2-4
2.8	Comprehensive calibration	2-4
2.8.1	Recommended equipment for comprehensive calibration.....	2-4
2.8.2	Front panel comprehensive calibration	2-4
2.8.3	IEEE-488 bus comprehensive calibration.....	2-9
2.9	AC self-calibration	2-12
2.9.1	Front panel AC calibration.....	2-12
2.9.2	IEEE-488 bus AC self-calibration	2-13

2.10	Low-level calibration.....	2-13
2.10.1	Recommended equipment for low-level calibration	2-13
2.10.2	Low-level calibration summary.....	2-13
2.10.3	Front panel low-level calibration procedure.....	2-16
2.10.4	IEEE-488 bus low-level calibration procedure	2-20
2.11	Single-point calibration	2-24
2.11.1	Front panel single-point calibration.....	2-24
2.11.2	IEEE-488 bus single-point calibration	2-24

3 Calibration Command Reference

3.1	Introduction	3-1
3.2	Commands.....	3-1
3.2.1	Command summary.....	3-1
3.3	:CALibration:PROTeCted Subsystem	3-3
3.3.1	:INIT	3-3
3.3.2	:LOCK	3-3
3.3.3	:SWITCh?.....	3-4
3.3.4	:SAVE.....	3-4
3.3.5	:DATA?	3-4
3.3.6	:DATE	3-5
3.3.7	:NDUE.....	3-5
3.3.8	:DC	3-6
3.3.9	:LLEVel.....	3-11
3.4	:CALibration:UNPRotected Subsystem	3-13
3.4.1	:ACCompensation	3-13
3.5	Bus error reporting	3-13
3.5.1	Calibration error summary	3-13
3.5.2	Detecting Calibration Errors.....	3-13
3.6	Detecting calibration step completion	3-14
3.6.1	Using the *OPC? Query	3-14
3.6.2	Using the *OPC command	3-14
3.6.3	Generating an SRQ on calibration complete	3-14

APPENDICES

A	Specifications	A-1
B	Calibration Programs.....	B-1
C	Calibration Messages.....	C-1
D	Calibration Command Summary	D-1

List of Illustrations

1 Performance Verification

Figure 1-1	Connections for DC volts verification	1-5
Figure 1-2	Connections for AC volts verification (all except 2MHz).....	1-7
Figure 1-3	Connections for 2MHz AC volts verification.....	1-7
Figure 1-4	Connections for DC current verification.....	1-11
Figure 1-5	Connections for AC current verification.....	1-12
Figure 1-6	Connections for resistance verification (20 Ω -2M Ω ranges).....	1-14
Figure 1-7	Connections for resistance verification (20M Ω and 200M Ω ranges).....	1-14
Figure 1-8	1G Ω resistor test box construction.....	1-15
Figure 1-9	Connections for frequency accuracy verification	1-16

2 Calibration

Figure 2-1	Low-thermal short connections.....	2-5
Figure 2-2	Calibrator connections for DC volts and ohms portion of comprehensive calibration.....	2-6
Figure 2-3	Connections for amps comprehensive calibration	2-8
Figure 2-4	Calibrator voltage connections.....	2-18
Figure 2-5	Synthesizer connections	2-20

APPENDICES

Figure B-1	Low-thermal short connections.....	B-3
Figure B-2	Connections for comprehensive calibration.....	B-4
Figure B-3	Calibrator voltage connections.....	B-4
Figure B-4	Calibrator current connections	B-4
Figure B-5	Synthesizer connections	B-5

List of Tables

1	Performance Verification	
Table 1-1	Recommended Test Equipment for Performance Verification	1-3
Table 1-2	Limits for DCV verification	1-5
Table 1-3	Limits for normal mode AC voltage verification	1-8
Table 1-4	Limits for low-frequency mode AC voltage verification	1-9
Table 1-5	Limits for AC peak voltage verification	1-10
Table 1-6	Limits for DC current verification	1-11
Table 1-7	Limits for AC current verification	1-13
Table 1-8	Limits for resistance verification (20 Ω -200M Ω ranges)	1-15
Table 1-9	Limits for resistance verification (1G Ω range)	1-15
Table 1-10	Frequency verification limits	1-16
Table 1-11	Thermocouple temperature reading checks	1-17
Table 1-12	RTD probe temperature reading checks	1-18
2	Calibration	
Table 2-1	IEEE-488 bus calibration command summary	2-3
Table 2-2	Recommended equipment for comprehensive calibration	2-4
Table 2-3	Front panel comprehensive calibration summary	2-5
Table 2-4	IEEE-488 bus comprehensive calibration summary	2-9
Table 2-5	Ohms calibration summary	2-11
Table 2-6	Amps calibration summary	2-12
Table 2-7	Recommended equipment for low-level calibration	2-14
Table 2-8	Low-level calibration summary	2-15
Table 2-9	Ohms calibration summary	2-22
Table 2-10	Amps calibration summary	2-22
3	Calibration Command Reference	
Table 3-1	IEEE-488 bus calibration command summary	3-2
Table 3-2	Comprehensive calibration commands	3-6
Table 3-3	Low-level calibration commands	3-11
	Appendices	
Table B-1	Recommended equipment for comprehensive calibration	B-2
Table B-2	Recommended equipment for low-level calibration	B-2
Table C-1	Calibration error messages	C-2
Table C-2	Calibration constants returned by :CAL:PROT:DATA? query	C-4
Table D-1	Calibration commands	D-1

Performance Verification

1.1 Introduction

The procedures in this section are intended to verify that Model 2002 accuracy is within the limits stated in the instrument one-year accuracy specifications. These procedures can be performed when the instrument is first received to ensure that no damage or misadjustment has occurred during shipment. Verification may also be performed whenever there is a question of instrument accuracy, or following calibration, if desired.

NOTE

If the instrument is still under warranty, and its performance is outside specified limits, contact your Keithley representative or the factory to determine the correct course of action.

This section includes the following:

- 1.2 **Environmental conditions:** Covers the temperature and humidity limits for verification.
- 1.3 **Warm-up period:** Describes the length of time the Model 2002 should be allowed to warm up before testing.
- 1.4 **Line power:** Covers power line voltage ranges during testing.
- 1.5 **Recommended equipment:** Summarizes recommended equipment and pertinent specifications.
- 1.6 **Verification limits:** Explains how reading limits were calculated.

- 1.7 **Restoring factory default conditions:** Gives step-by-step procedures for restoring default conditions before each test procedure.

- 1.8 **Verification procedures:** Details procedures to verify measurement accuracy of all Model 2002 measurement functions.

1.2 Environmental conditions

Verification measurements should be made at an ambient temperature of 18–28°C (65–82°F), and at a relative humidity of less than 80% unless otherwise noted.

1.3 Warm-up period

The Model 2002 must be allowed to warm up for the following time period before performing the verification procedures:

- DC volts and ohms: four hours
- AC volts, AC current, DC current: one hour

If the instrument has been subjected to temperature extremes (outside the range stated in paragraph 1.2), allow additional time for internal temperatures to stabilize. Typically, it takes one additional hour to stabilize a unit that is 10°C (18°F) outside the specified temperature range.

The test equipment should also be allowed to warm up for the minimum period specified by the manufacturer.

1.4 Line power

The Model 2002 should be tested while operating from a line voltage in the range of 90–134V or 180–250V at a frequency of 50, 60, or 400Hz.

1.5 Recommended test equipment

Table 1-1 lists all test equipment required for verification. Alternate equipment may be used as long as that equipment has specifications at least as good as those listed in the table.

NOTE

The calibrator listed in Table 1-1 is sufficiently accurate to verify Model 2002 accuracy to total factory calibration uncertainty. It is not accurate enough to verify Model 2002 relative accuracy specifications alone.

1.6 Verification limits

The verification limits stated in this section have been calculated using the Model 2002 one-year relative accuracy specifications and the total absolute uncertainty of the factory recommended calibrator (see Table 1-1). DCV, DCI, and ohms limits also include factory calibration uncertainty. (See specifications.) Those who are using calibration sources with better absolute uncertainty should recalculate the limits using the Model 2002 relative accuracy specifications, the absolute uncertainty specifications of the calibration sources, and factory calibration uncertainty (DCV, DCI, and ohms).

1.6.1 Reading limit calculation example

As an example of how reading limits are calculated, assume that the 20VDC range is being tested using a 19V input value, and the various specifications are as follows:

- Model 2002 relative accuracy: $\pm(10\text{ppm of reading} + 0.15\text{ppm of range})$
- Model 2002 factory calibration uncertainty: $\pm 2.6\text{ppm of reading}$
- Calibrator total absolute uncertainty at 19V output: $\pm 5.4\text{ppm}$

The calculated limits are:

$$\text{Reading limits} = 19\text{V} \pm [(19\text{V} \times (10\text{ppm} + 2.6\text{ppm})) + (20\text{V} \times 0.15\text{ppm}) + 19\text{V} \times 5.4\text{ppm}]$$

$$\text{Reading limits} = 19\text{V} \pm 0.000345\text{V}$$

$$\text{Reading limits} = 18.999655\text{V to } 19.000345\text{V}$$

1.6.2 Additional derating factors

Certain functions and ranges are subject to certain derating factors that must be included when calculating reading limits. For example, coupling errors must be added to low-frequency AC limits, while AC voltage limits for inputs above 100V are subject to additional derating factors.

Always read the associated specification notes to determine if any derating factors apply before calculating reading limits.

1.7 Restoring default conditions

Before performing each performance verification procedure, restore instrument bench default conditions as follows:

1. From the normal display mode, press the MENU key. The instrument will display the following:
MAIN MENU
SAVESETUP GPIB CALIBRATION
2. Select SAVESETUP, and press ENTER. The following will be displayed:
SETUP MENU
SAVE RESTORE POWERON RESET
3. Select RESET, and press ENTER. The display will then appear as follows:
RESET ORIGINAL DFLTS
BENCH GPIB
4. Select BENCH, then press ENTER. The following will be displayed:
RESETTING INSTRUMENT
ENTER to confirm; EXIT to abort
5. Press ENTER again to confirm instrument reset. The instrument will return to the normal display with bench defaults restored.

Table 1-1
Recommended Test Equipment for Performance Verification

Mfg.	Model	Description	Specifications*
Fluke	5700A	Calibrator	<p>±5ppm basic uncertainty.</p> <p>DC Voltage: 190mV: ±11ppm 1.9V: ±7ppm 19V: ±5ppm 190V: ±7ppm 1000V: ±9ppm</p> <p>AC Voltage, 10Hz-1MHz (40Hz-20kHz specifications): 190mV: ±150ppm 1.9V: ±78ppm 19V: ±78ppm 190V: ±85ppm 750V: ±85ppm (50Hz-1kHz)</p> <p>DC current: 190μA: ±103ppm 1.9mA: ±55ppm 19mA: ±55ppm 190mA: ±65ppm 1.9A: ±96ppm</p> <p>AC Current, 40Hz-10kHz (40Hz-1kHz specifications): 190μA: ±245ppm 1.9mA: ±160ppm 19mA: ±160ppm 190mA: ±170ppm 1.9A: ±670ppm</p> <p>Resistance: 19Ω: ±26ppm 190Ω: ±17ppm 1.9kΩ: ±12ppm 19kΩ: ±11ppm 190kΩ: ±13ppm 1.9MΩ: ±19ppm 19MΩ: ±47ppm 100MΩ: ±120ppm</p>
Fluke	5725A	Amplifier	AC Voltage, 1kHz-10kHz: 750V: ±85ppm
Fluke	5700A-03	Wideband AC option	190mV ± 0.22%, 1.9V ± 0.3% @ 2MHz
Fluke	5440A-7002	Low-thermal cable set	
Keithley	CA-18-1	Low-capacitance cable	Low-capacitance dual banana to dual banana shielded cable (for ACV), 1.2m (4 ft.) in length.
Keithley	R-289-1G	1GΩ resistor	NOTE: Resistor should be characterized to within ±1,000ppm and mounted in shielded test box (see procedure).
		Metal component box (for 1GΩ resistor)	
		Banana plugs (2) for test box	One insulated, one non-insulated.
Keithley	3940	Multifunction Synthesizer	1Hz-15MHz, ±5ppm
General Radio	1433-T	Precision Decade Resistance Box	10-400Ω, ±0.02%
—	—	Megaohmmeter	1GΩ, ±0.5%

* 90-day calibrator specifications shown include total absolute uncertainty at specified output.

1.8 Verification procedures

The following paragraphs contain procedures for verifying instrument accuracy specifications for the following measuring functions:

- DC volts
- AC volts
- DC current
- AC current
- Resistance
- Frequency
- Temperature

NOTE

The following verification procedures are intended to verify the accuracy of the Model 2002 and include reading limits based on the Model 2002 relative accuracy specifications and the total uncertainty of the recommended calibrator. DCV, DCI, and ohms limits include factory calibration uncertainty.

If the Model 2002 is out of specifications and not under warranty, refer to the calibration procedures in Section 2.

WARNING

The maximum common-mode voltage (voltage between INPUT LO and chassis ground) is 500V peak. Exceeding this value may cause a breakdown in insulation, creating a shock hazard. Some of the procedures in this section may expose you to dangerous voltages. Use standard safety precautions when such dangerous voltages are encountered to avoid personal injury caused by electric shock.

NOTE

Do not connect test equipment to the Model 2002 through a scanner or other switching equipment.

1.8.1 DC volts verification

DC voltage accuracy is verified by applying accurate DC voltages from a calibrator to the Model 2002 input and verifying that the displayed readings fall within specified ranges.

Follow the steps below to verify DCV measurement accuracy.

CAUTION

Do not exceed 1100V peak between INPUT HI and INPUT LO, or instrument damage may occur.

1. Connect the Model 2002 to the calibrator, as shown in Figure 1-1. Be sure to connect calibrator HI to Model 2002 INPUT HI and calibrator LO to Model 2002 INPUT LO as shown.

NOTE

Use shielded, low-thermal connections when testing the 200mV and 2V ranges to avoid errors caused by noise or thermal offsets. Connect the shield to calibrator output LO.

2. Turn on the Model 2002 and the calibrator, and allow a four-hour warm-up period before making measurements.
3. Restore Model 2002 factory default conditions, as explained in paragraph 1.7.
4. Set Model 2002 operating modes as follows:
 - A. From normal display, press CONFIG then DCV.
 - B. Select SPEED, then press ENTER.
 - C. Select HIACCURACY, then press ENTER.
 - D. Select FILTER, then press ENTER.
 - E. Select AVERAGING, then press ENTER.
 - F. Using the cursor and range keys, set the averaging parameter to 10 readings, then press ENTER.
 - G. Press EXIT to return to normal display.
5. Select the Model 2002 200mV DC range. (If the FILT annunciator is off, press the FILTER key to enable the filter.)

NOTE

Do not use auto-ranging for any of the verification tests because auto-range hysteresis may cause the Model 2002 to be on an incorrect range.

6. Set the calibrator output to 0.00000mVDC, and allow the reading to settle.
7. Enable the Model 2002 REL mode. Leave REL enabled for the remainder of the DC volts verification test.
8. Set the calibrator output to +190.00000mVDC, and allow the reading to settle.
9. Verify that the Model 2002 reading is within the limits summarized in Table 1-2.
10. Repeat steps 8 and 9 for the remaining ranges and voltages listed in Table 1-2.
11. Repeat the procedure for each of the ranges with negative voltages of the same magnitude as those listed in Table 1-2.

Table 1-2
Limits for DCV verification

2002 DCV Range	Applied DC Voltage	Reading Limits (1 year, 18° to 28°C)
200mV	190.000000mV	189.991911mV to 190.008089mV
2V	1.90000000V	1.89996058 to 1.90003942V
20V	19.0000000V	18.9996550V to 19.0003450V
200V	190.000000V	189.993691V to 190.006309V
1000V	1000.0000V	999.94640V to 1000.05360V

NOTES:

1. Repeat procedure for negative voltages of same magnitude.
2. Reading limits shown include total absolute uncertainty of recommended calibrator (see Table 1-1) and factory calibration uncertainty (see specifications).

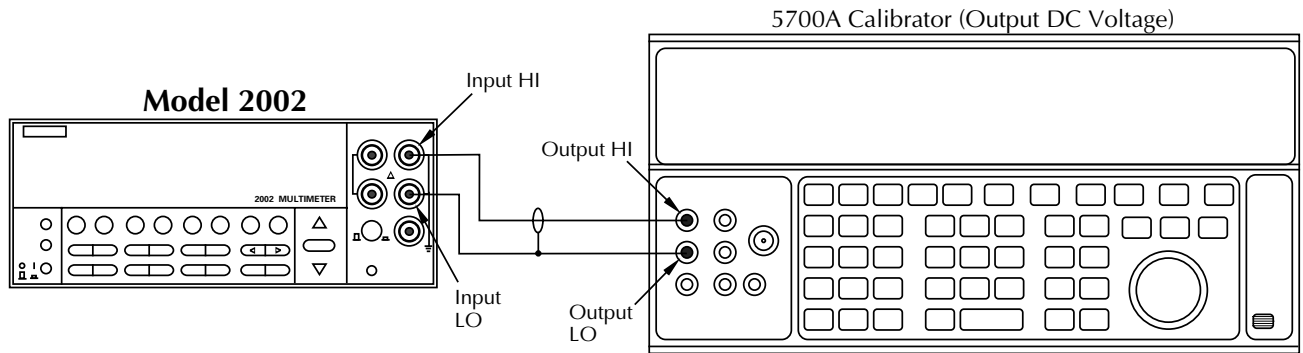

Note : Use shielded, low-thermal cables when testing 200mV and 2V ranges.

Figure 1-1
Connections for DC volts verification

1.8.2 AC volts verification

AC voltage accuracy is checked by applying accurate AC voltages at specific frequencies from an AC calibration source and then verifying that each Model 2002 AC voltage reading falls within the specified range. The two ACV verification procedures that follow include:

- Normal Mode
- Low-frequency Mode

CAUTION

Do not exceed 1100V peak between INPUT HI and INPUT LO, or $2 \times 10^7 \text{V} \cdot \text{Hz}$ input, or instrument damage may occur.

Normal mode

1. Turn on the Model 2002, calibrator, and amplifier, and allow a one-hour warm-up period before making measurements.
2. Connect the Model 2002 to the calibrator, as shown in Figure 1-2. Be sure to connect amplifier HI to Model 2002 INPUT HI and amplifier LO to Model 2002 INPUT LO as shown. Connect the power amplifier to the calibrator using the appropriate connector on the rear of the calibrator.
3. Restore Model 2002 factory default conditions, as explained in paragraph 1.7.

4. Select the ACV function and the 200mV range on the Model 2002, and make sure that REL is disabled.

NOTE

Do not use REL to null offsets when performing AC volts tests. Also, do not enable the filter.

5. Set the calibrator output to 190.000mVAC at a frequency of 100Hz, and allow the reading to settle.
6. Verify that the Model 2002 reading is within the limits summarized in Table 1-3.
7. Repeat steps 5 and 6 for 190mVAC at the remaining frequencies listed in Table 1-3 (except 2MHz). Verify that instrument readings fall within the required limits listed in the table.
8. Repeat steps 5 through 7 for the 2V, 20V, 200V, and 750VAC ranges using the input voltages and limits stated in Table 1-3.
9. Connect the Model 2002 to the wideband calibrator output (see Figure 1-3).
10. Set the calibrator output to 190.000mV at a frequency of 2MHz.
11. Verify that the reading is within the limits shown in Table 1-3.
12. Repeat steps 10 and 11 for 1.90000V input on the 2V range.

CAUTION

Do not attempt to test the 20V–1000V ranges at 2MHz.

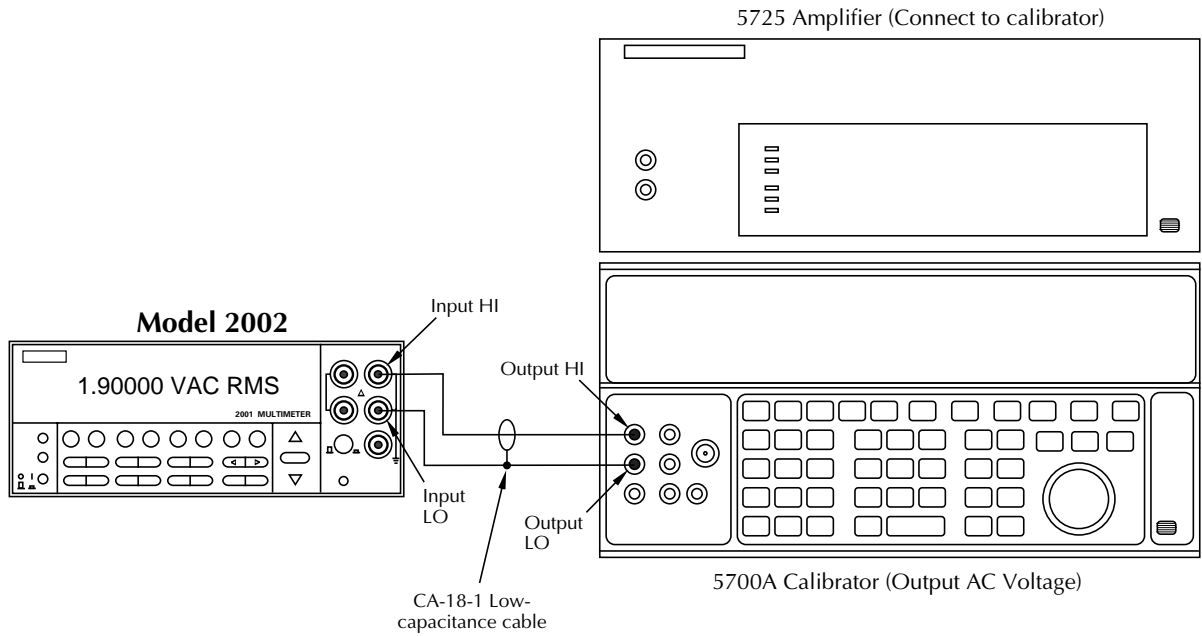

Figure 1-2
Connections for AC volts verification (all except 2MHz)

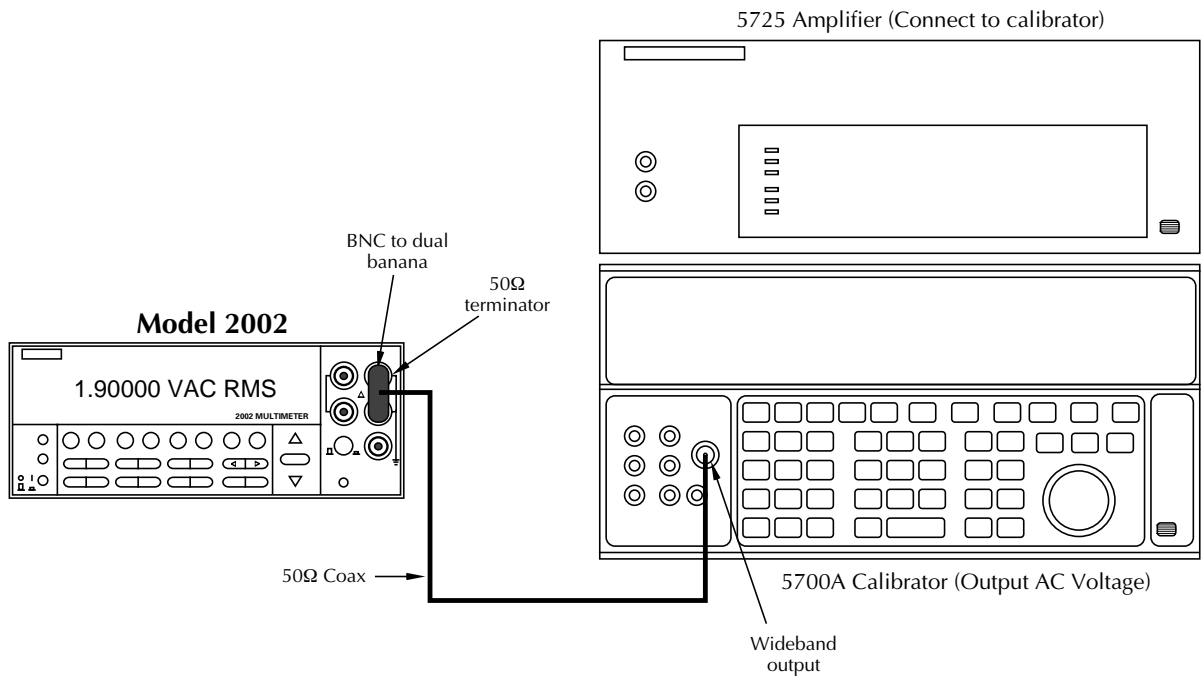

Figure 1-3
Connections for 2MHz AC volts verification

Table 1-3
Limits for normal mode AC voltage verification

		Reading limits (1 year, 18°C to 28°C)												
		100Hz	1kHz	5kHz	25kHz	50kHz	100kHz	200kHz	1MHz	2MHz				
2002 ACV range	Applied voltage													
200mV	190.000mV	189.914mV to 190.087mV	189.942mV to 190.058mV	189.942mV to 190.058mV	189.933mV to 190.068mV	189.885mV to 190.115mV	189.400mV to 190.600mV	188.525mV to 191.475mV	186.000mV to 194.000mV	180.100mV to 199.900mV				
2V	1.90000V	1.89914V to 1.90087V	1.89942V to 1.90058V	1.89942V to 1.90058V	1.89933V to 1.90068V	1.89885V to 1.90115V	1.89400V to 1.90600V	1.88525V to 1.91475V	1.86000V to 1.94000V	1.80100V to 1.99900V				
20V	19.0000V	18.9885V to 19.0116V	18.9913V to 19.0087V	18.9894V to 19.0106V	18.9875V to 19.0125V	18.9837V to 19.0163V	18.9400V to 19.0600V	18.8525V to 19.1475V	18.2000V to 19.8000V	*				
200V	190.000V	189.878V to 190.122V	189.906V to 190.094V	189.887V to 190.113V	189.868V to 190.132V	189.830V to 190.170V	189.393V to 190.607V	*	*	*				
750V	750.00V	748.98V to 751.02V	749.09V to 750.91V	749.02V to 750.98V	748.87V to 751.13V	*	*	*	*	*				

* CAUTION: Do not exceed 2×10^7 V•Hz input.

** Use wideband option and connections for 2MHz tests.

NOTE: Reading limits shown include total absolute uncertainty of recommended calibrator (see Table 1-1). Reading limits also include the adder for AC Coupling of the input.

Low-frequency mode

1. Turn on the Model 2002, calibrator, and amplifier, and allow a one-hour warm-up period before making measurements.
2. Connect the Model 2002 to the calibrator, as shown in Figure 1-2. Be sure to connect the amplifier HI to Model 2002 INPUT HI and amplifier LO to Model 2002 INPUT LO as shown. Connect the power amplifier to the calibrator using the appropriate connector on the rear of the calibrator.
3. Restore Model 2002 factory default conditions, as explained in paragraph 1.7.
4. Select the ACV function and the 200mV range on the Model 2002, and make sure that REL is disabled.
5. Select the low-frequency mode as follows:
 - A. Press CONFIG ACV, select AC-TYPE, then press ENTER.
 - B. Select LOW-FREQ-RMS, then press ENTER.
 - C. Press EXIT as required to return to normal display.
6. Set the calibrator output to 190.000mVAC at a frequency of 10Hz, and allow the reading to settle.
7. Verify that the Model 2002 reading is within the limits summarized in Table 1-4.
8. Repeat steps 6 and 7 for 190mVAC at the remaining frequencies listed in the table.
9. Repeat steps 6 through 8 for the 2V, 20V, 200V, and 750VAC ranges, using the input voltages and limits stated in Table 1-4.

NOTE

Do not use REL to null offsets when performing AC volts tests. Also, do not enable the filter.

Table 1-4
Limits for low-frequency mode AC voltage verification

2002 ACV range	Applied voltage	Reading limits (1 year, 18°C to 28°C)		
		10Hz	50Hz	100Hz
200mV	190.000mV	189.837mV to 190.163mV	189.904mV to 190.097mV	189.923mV to 190.077mV
2V	1.90000V	1.89875V to 1.90125V	1.89923V to 1.90078V	1.89942V to 1.90058V
20V	19.0000V	18.9837V to 19.0163V	18.9904V to 19.0097V	18.9913V to 19.0087V
200V	190.000V	189.849V to 190.151V	189.906V to 190.094V	189.906V to 190.094V
750V	750.00V	*	749.09V to 750.91V	749.09V to 750.91V

* Recommended calibrator/amplifier cannot source this voltage/frequency.

Notes:

1. Specifications above 100Hz are the same as normal mode.
2. Limits shown include total absolute uncertainty of recommended calibrator (see Table 1-1).

AC peak mode

1. Turn on the Model 2002, calibrator, and amplifier, and allow a one-hour warm-up period before making measurements.
2. Connect the Model 2002 to the calibrator, as shown in Figure 1-2. Be sure to connect the amplifier HI to Model 2002 INPUT HI, and the amplifier LO to MODEL 2002 INPUT LO as shown. Connect the power amplifier to the calibrator using the appropriate connector on the rear of the calibrator.
3. Restore the Model 2002 factory default conditions.
4. Select the ACV function and the 200mV range on the Model 2002, and make sure that REL is disabled.

NOTE

Do not use REL to null offsets when performing AC volts tests. Use AC coupling for 5kHz-1MHz tests. Use AC+DC coupling for 20Hz tests. (Use CONFIG-ACV to set up coupling).

5. Select the AC peak and filter modes as follows:
 - A. Press CONFIG then ACV, select AC-TYPE, then press ENTER.

- B. Select PEAK, then press ENTER.
 - C. Select FILTER, then press ENTER.
 - D. Select AVERAGING, then press ENTER.
 - E. Using the cursor and range keys, set the averaging parameter to 10 readings, then press ENTER.
 - F. Press EXIT as necessary to return to normal display.
 - G. If the FLT annunciator is off, press FILTER to enable the filter.
6. Set the calibrator output to 100.000mVAC at a frequency of 5kHz, and allow the reading to settle.
 7. Verify that the Model 2002 reading is within the limits summarized in Table 1-5.
 8. Repeat steps 6 and 7 for 100mVAC at the remaining frequencies listed in the table.
 9. Repeat steps 6 through 8 for the 2V, 20V, 200V, and 750VAC ranges, using the input voltages and limits stated in Table 1-6.

CAUTION

Do not apply more than 400V at 50kHz, 80V at 250kHz, 40V at 500kHz, or 20V at 1MHz, or instrument damage may occur.

10. Set input coupling to AC+DC, then repeat the procedure for a 20Hz input signal.

Table 1-5
Limits for AC peak voltage verification

2002 ACV range	Applied voltage*	Allowable readings (1 year, 18°C to 28°C)								
		20Hz†	5kHz	25kHz	50kHz	100kHz	250kHz	500kHz	750kHz	1MHz
200mV	100mV	139.9mV to 142.9mV	139.9mV to 142.9mV	139.9mV to 143.0mV	139.8mV to 143.0mV	139.7mV to 143.2mV	138.6mV to 144.2mV	136.5mV to 146.4mV	132.2mV to 150.6mV	127.3mV to 155.5mV
2V	1V	1.407V to 1.421V	1.407V to 1.421V	1.407V to 1.422V	1.406V to 1.422V	1.405V to 1.424V	1.394V to 1.434V	1.373V to 1.456V	1.330V to 1.498V	1.281V to 1.547V
20V	10V	13.99V to 14.30V	13.99V to 14.30V	13.98V to 14.30V	13.98V to 14.31V	13.97V to 14.32V	13.86V to 14.42V	13.65V to 14.64V	13.22V to 15.06V	12.73V to 15.55V
200V	100V	140.7V to 142.2V	140.7V to 142.2V	140.6V to 142.2V	140.6V to 142.3V	140.5V to 142.4V	**	**	**	**
750V	500V	—	701.3V to 712.9V	701.0V to 713.2V	**	**	**	**	**	**

* Calibrator voltage is given as an RMS value. Model 2002 reading limits are peak AC values.

** CAUTION: Do not apply more than $2 \times 10^7 \text{V}\cdot\text{Hz}$.

† Use AC+DC input coupling for 20Hz tests only. (Use CONFIG-ACV to set coupling.)

NOTE: Limits shown include uncertainty of recommended calibrator.

1.8.3 DC current verification

DC current accuracy is checked by applying accurate DC currents from a calibrator to the instrument AMPS input and then verifying that the current readings fall within appropriate limits.

Follow the steps below to verify DCI measurement accuracy.

CAUTION

Do not apply more than 2A, 250V to the AMPS input, or the amps protection fuse will blow.

1. Connect the Model 2002 to the calibrator, as shown in Figure 1-4. Be sure to connect calibrator HI to the AMPS input, and connect calibrator LO to INPUT LO as shown.
2. Turn on the Model 2002 and the calibrator, and allow a one-hour warm-up period before making measurements. Be sure the calibrator is set for normal current output.
3. Restore Model 2002 factory default conditions, as explained in paragraph 1.7.
4. Set digital filter averaging as follows:
 - A. From normal display, press CONFIG then DCI.
 - B. Select FILTER, then press ENTER.
 - C. Select AVERAGING, then press ENTER.
 - D. Using the cursor and range keys, set the averaging parameter to 10 readings, then press ENTER.

- E. Press EXIT as necessary to return to normal display.
5. Select the DC current function (DCI) and the 200 μ A range on the Model 2002. (If the FILT annunciator is off, press the FILTER key to enable the filter.)
6. Set the calibrator output to +190.0000 μ ADC, and allow the reading to settle.
7. Verify that the Model 2002 reading is within the limits summarized in Table 1-6.
8. Repeat steps 6 and 7 for the remaining ranges and currents listed in Table 1-6.
9. Repeat the procedure for each of the ranges with negative currents of the same magnitude as those listed in Table 1-6.

Table 1-6

Limits for DC current verification

2002 DCI range	Applied DC current	Reading limits (1 year, 18°C to 28°C)
200 μ A	190.0000 μ A	189.9010 μ A to 190.0990 μ A
2mA	1.900000mA	1.899114mA to 1.900886mA
20mA	19.000000mA	18.99085mA to 19.00915mA
200mA	190.0000mA	189.8816mA to 190.1184mA
2A	1.900000A	1.898108A to 1.901892A

NOTES:

1. Repeat procedure for negative currents.
2. Reading limits shown include total absolute uncertainty of recommended calibrator (see Table 1-1) and factory calibration uncertainty (see specifications).

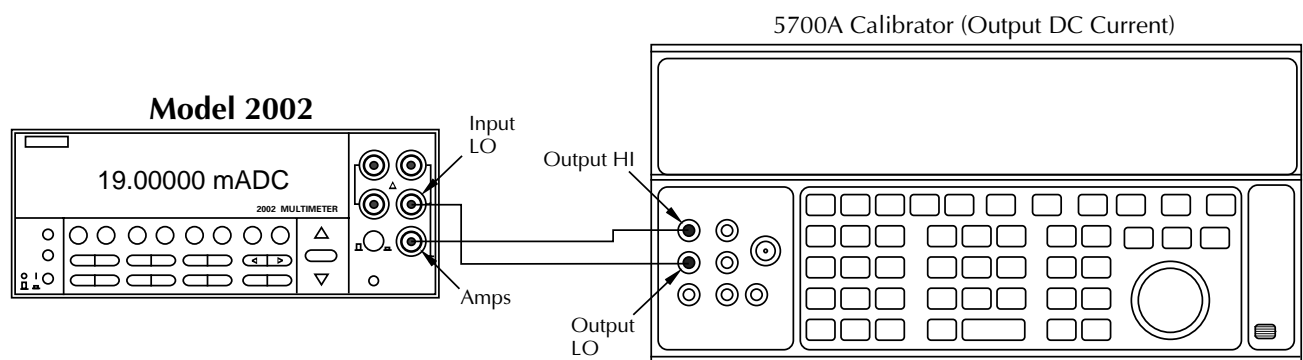

Note: Be sure calibrator is set for normal current output.

Figure 1-4
Connections for DC current verification

1.8.4 AC current verification

AC current verification is performed by applying accurate AC currents at specific frequencies and then verifying that Model 2002 readings fall within specified limits.

Follow the steps below to verify ACI measurement accuracy.

CAUTION

Do not apply more than 2A, 250V to the AMPS input, or the current protection fuse will blow.

1. Connect the Model 2002 to the calibrator, as shown in Figure 1-5. Be sure to connect calibrator HI to the AMPS input, and connect calibrator LO to INPUT LO as shown.

2. Turn on the Model 2002 and the calibrator, and allow a one-hour warm-up period before making measurements. Be sure the calibrator is set for normal current output.
3. Restore Model 2002 factory default conditions, as explained in paragraph 1.7.
4. Select the AC current function and the 200 μ A range on the Model 2002.
5. Set the calibrator output to 190.000 μ A AC at a frequency of 40Hz, and allow the reading to settle.
6. Verify that the Model 2002 reading is within the limits for the present current and frequency summarized in Table 1-7.
7. Repeat steps 5 and 6 for each frequency listed in Table 1-7.
8. Repeat steps 5 through 7 for the remaining ranges and frequencies listed in Table 1-7.

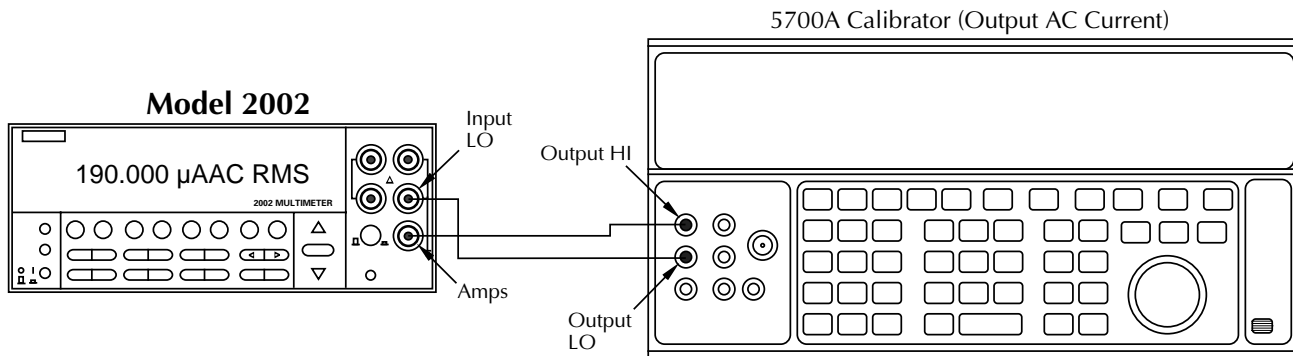

Note: Be sure calibrator is set for normal current output.

Figure 1-5
Connections for AC current verification

Table 1-7
Limits for AC current verification

2002 ACI range	Applied AC current	Reading limits (1 year, 18°C to 28°C)			
		40Hz	100Hz	1kHz	10kHz
200 μ A	190.000 μ A	188.260mV to 191.740mV	189.562mV to 190.439mV	189.210mV to 190.790mV	189.020mV to 190.980mV
2mA	1.90000mA	1.88355V to 1.91645V	1.89657V to 1.90344V	1.89742V to 1.90258V	1.89742V to 1.90258V
20mA	19.0000mA	18.8355V to 19.1645V	18.9657V to 19.0344V	18.9742V to 19.0258V	18.9742V to 19.0258V
200mA	190.000mA	188.355V to 191.645V	189.657V to 190.344V	189.742V to 190.258V	189.685V to 190.315V
2A	1.90000A	1.88250V to 1.91750V	1.89552V to 1.90449V	1.89390V to 1.90610V	1.89105V to 1.90895V

NOTE: Reading limits shown include total absolute uncertainty of recommended calibrator (see Table 1-1).

1.8.5 Resistance verification

Resistance verification is performed by connecting accurate resistance values to the instrument and verifying that Model 2002 resistance readings are within stated limits.

Follow the steps below to verify resistance measurement accuracy.

CAUTION

Do not apply more than 1100V peak between INPUT HI and LO or more than 150V peak between SENSE HI and LO, or instrument damage may occur.

20 Ω – 2M range verification

- Using shielded 4-wire connections, connect the Model 2002 to the calibrator, as shown in Figure 1-6. Be sure to connect calibrator HI and LO terminals to the Model 2002 HI and LO terminals (including SENSE HI and LO) as shown.
- Turn on the Model 2002 and the calibrator, and allow a four-hour warm-up period before making measurements.
- Set the calibrator for 4-wire resistance (external sense on).
- Restore Model 2002 factory default conditions, as explained in paragraph 1.7.

- Set Model 2002 operating modes as follows:
 - From normal display, press CONFIG then Ω 4.
 - Select SPEED, then press ENTER.
 - Select HIACCURACY, then press ENTER.
 - Select FILTER, then press ENTER.
 - Select AVERAGING, then press ENTER.
 - Using the cursor and range keys, set the averaging parameter to 10 readings, then press ENTER.
 - Select OFFSETCOMP, then press ENTER.
 - Select ON, then press ENTER. (Note that OFFSETCOMP cannot be used with the 200k Ω and 2M Ω ranges.)
 - Press EXIT to return to normal display.
- Select the Ω 4 function, and place the instrument on the 20 Ω range. (If the FILT annunciator is off, press the FILTER key to enable the filter.)
- Set the calibrator to output 19 Ω , and allow the reading to settle. Verify that the reading is within the limits stated in Table 1-8.

NOTE

Resistance values available in the Model 5700A calibrator may be slightly different than the stated nominal resistance values. Limits stated in Table 1-8 should be recalculated based on actual calibrator resistance values.

8. Set the calibrator output to 190Ω , and allow the reading to settle.
9. Verify that the reading is within the limits stated in Table 1-8. (NOTE: Recalculate limits if calibrator resistance is not exactly as listed.)
10. Repeat steps 8 and 9 for the $2k\Omega$ through $2M\Omega$ ranges using the values listed in Table 1-8. (Do not use offset compensation for the $200k\Omega$ and $2M\Omega$ ranges.)

20M Ω and 200M Ω range verification

1. Connect the DC calibrator and Model 2002 using the 2-wire connections shown in Figure 1-7.
2. Set the calibrator to the 2-wire mode (external sense off).
3. Set Model 2002 operating modes as follows:

- A. From normal display, press CONFIG then Ω .
 - B. Select SPEED, then press ENTER.
 - C. Select HIACCURACY, then press ENTER.
 - D. Select FILTER, then press ENTER.
 - E. Select AVERAGING, then press ENTER.
 - F. Using the cursor and range keys, set the averaging parameter to 10 readings, then press ENTER.
 - G. Press EXIT to return to normal display.
4. Select the Model 2002 Ω function, and change to the $20M\Omega$ range. (If the FILT annunciator is off, press the FILTER key to enable the filter.)
 5. Set the calibrator to output $19M\Omega$, and allow the reading to settle.
 6. Verify that the reading is within the limits for the $20M\Omega$ range stated in Table 1-8. (NOTE: Recalculate limits if actual calibrator resistance differs from value shown.)
 7. Repeat steps 4 through 6 for the $200M\Omega$ range (output $100M\Omega$).

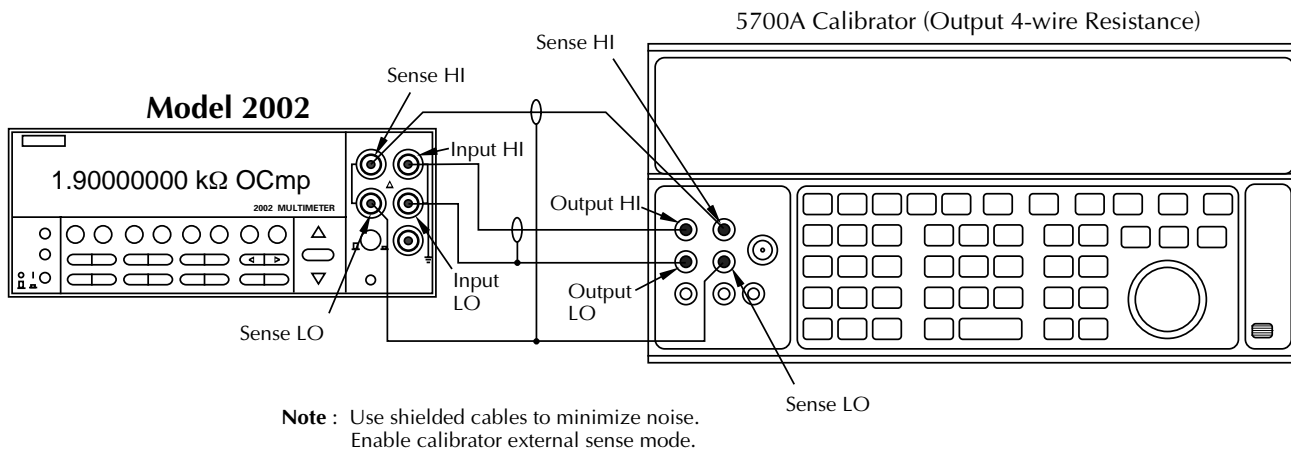

Figure 1-6
Connections for resistance verification (20Ω - $2M\Omega$ ranges)

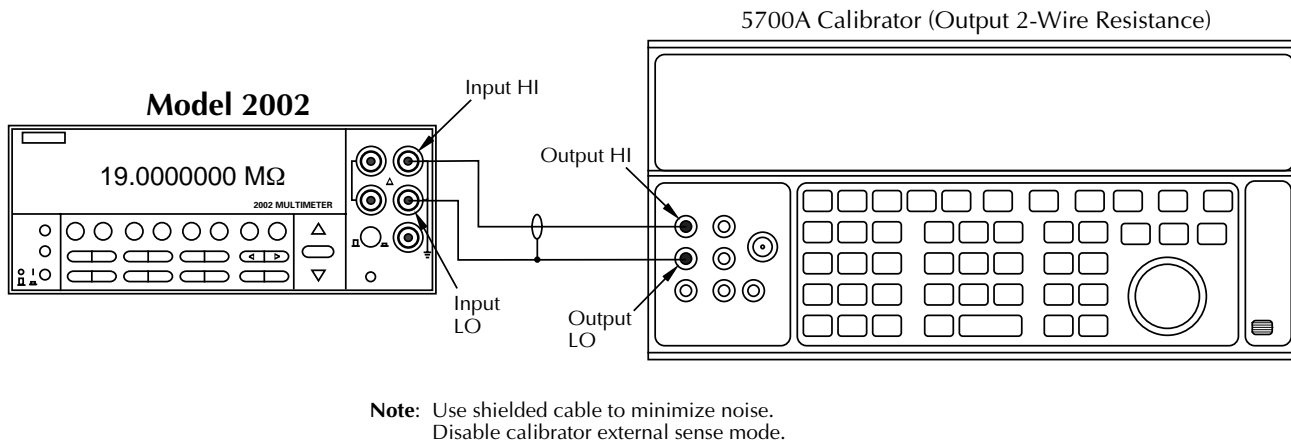

Figure 1-7
Connections for resistance verification ($20M\Omega$ and $200M\Omega$ ranges)

Table 1-8
Limits for resistance verification (20 Ω -200M Ω ranges)

2002 Ω range	Nominal applied resistance	Reading limits (1 year, 18°C to 28°C)
20 Ω	19 Ω	18.9985025 Ω to 19.0014975 Ω
200 Ω	190 Ω	189.991277 Ω to 190.008723 Ω
2k Ω	1.9k Ω	1.89994714k Ω to 1.90005286k Ω
20k Ω	19k Ω	18.9994638k Ω to 19.0005362k Ω
200k Ω	190k Ω	189.989313k Ω to 190.010687k Ω
2M Ω	1.9M Ω	1.89981109M Ω to 1.90018891M Ω
20M Ω	19M Ω	18.9940619M Ω to 19.0059381M Ω
200M Ω	100M Ω	99.930910M Ω to 100.069090M Ω

Notes:

- Limits shown include total absolute calibrator uncertainty (see Table 1-1) and factory calibration uncertainty (see specifications), and are based on nominal calibration values shown. Recalculate limits using Model 2002 relative accuracy specifications, factory calibration uncertainty, and calibrator absolute uncertainty if calibrator resistance values differ from nominal values shown.
- Use 4-wire connections and function for 20 Ω -2M Ω ranges. Use 2-wire connections and function for 20M Ω and 200M Ω ranges.

1G Ω range verification

- Mount the 1G Ω resistor and the banana plugs to the test box, as shown in Figure 1-8. Be sure to mount the banana plugs with the correct spacing. The resistor should be completely enclosed in and shielded by the metal test box. The resistor LO lead should be electrically connected to the test box to provide adequate shielding.

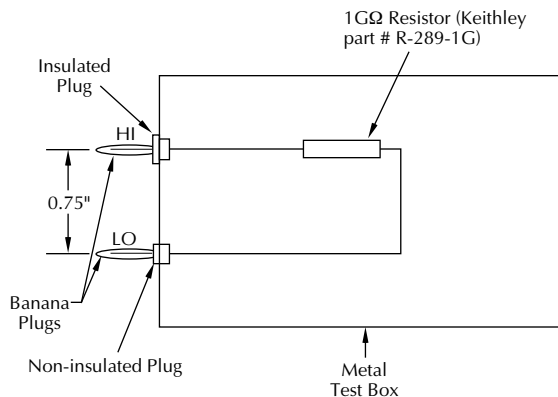

Note: Resistor must be accurately characterized before use (see text).

Figure 1-8
1G Ω resistor test box construction

- Characterize the 1G Ω resistor to within $\pm 1,000$ ppm or better using an accurate megohm bridge or similar equipment. Record the characterized value where indicated in Table 1-9. Also compute the limits based on the value of R using the formula at the bottom of the table.

NOTE

The actual value of the 1G Ω resistor should not exceed 1.05G Ω .

- Set Model 2002 operating modes as follows:
 - From normal display, press CONFIG then $\Omega 2$.
 - Select SPEED, then press ENTER.
 - Select HIACCURACY, then press ENTER.
 - Select FILTER, then press ENTER.
 - Select AVERAGING, then press ENTER.
 - Using the cursor and range keys, set the averaging parameter to 10 readings, then press ENTER.
 - Press EXIT to return to normal display.
- Select the 2-wire ohms function ($\Omega 2$) and the 1G Ω range on the Model 2002. (If the FILT annunciator is off, press the FILTER key to enable the filter.)
- Connect the 1G Ω resistor test box (from steps 1 and 2) to the INPUT HI and LO terminals of the Model 2002. (Be sure that the box shield is connected to INPUT LO.) Allow the reading to settle.
- Verify that the Model 2002 reading is within the limits you calculated and recorded in Table 1-9.

Table 1-9
Limits for resistance verification (1G Ω range)

Characterized resistor (R)	Reading limits (1 year, 18°C to 28°C)
_____ G Ω	_____ G Ω to _____ G Ω

* 1 year limits = $R \pm (0.002065R + 15,000)\Omega$

Where R = characterized value of 1G Ω resistor in ohms.

1.8.6 Frequency accuracy verification

Frequency accuracy verification is performed by connecting an accurate frequency source to Model 2002 inputs, and then verifying that the frequency readings are within stated limits.

Use the procedure below to verify the frequency measurement accuracy of the Model 2002.

- Connect the frequency synthesizer to the Model 2002 INPUT terminals, as shown in Figure 1-9.
- Turn on both instruments, and allow a one-hour warm-up period before measurement.

3. Set the synthesizer operating modes as follows:
 FREQ: 1Hz
 AMPTD: 5V p-p
 OFFSET: 0V
 MODE: CONT
 FCTN: sine
4. Restore Model 2002 factory defaults, as explained in paragraph 1.7.
5. Set maximum signal level to 10V as follows:
 - A. Press CONFIG then FREQ.
 - B. Select MAX-SIGNAL-LEVEL, then press ENTER.
 - C. Choose 10V, then press ENTER.
 - D. Press EXIT to return to normal display.
6. Press the FREQ key to select the frequency function.
7. Verify that the Model 2002 frequency reading is within the limits shown in the first line of Table 1-10.

8. Set the synthesizer to each of the frequencies listed in Table 1-10, and verify that the Model 2002 frequency reading is within the required limits.

Table 1-10
Frequency verification limits

Synthesizer frequency	Reading limits (1 year, 18°C to 28°C)
1Hz	0.9997Hz to 1.0003Hz
10Hz	9.9970Hz to 10.003Hz
100Hz	99.970Hz to 100.03Hz
1kHz	0.9997kHz to 1.0003kHz
10kHz	9.9970kHz to 10.003kHz
100kHz	99.970kHz to 100.03kHz
1MHz	0.9997MHz to 1.0003MHz
10MHz	9.9970MHz to 10.003MHz
15MHz	14.996MHz to 15.004MHz

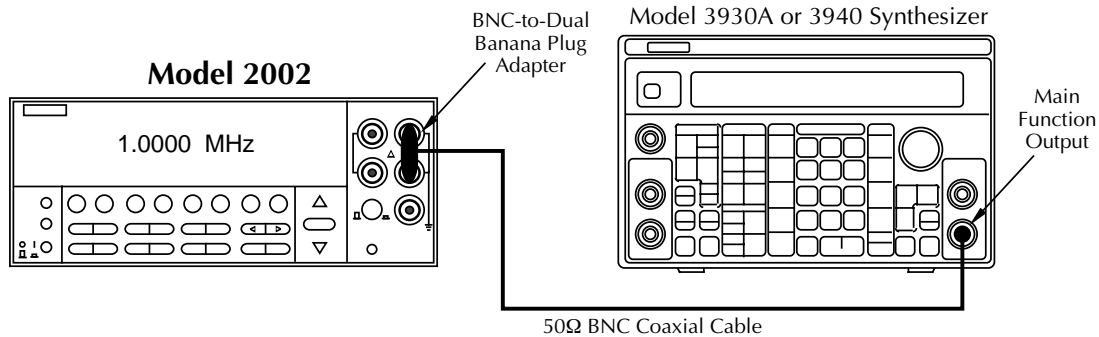

Figure 1-9
Connections for frequency accuracy verification

1.8.7 Temperature reading checks

When using thermocouples, the Model 2002 displays temperature by measuring the DC thermocouple voltage, and then calculating the corresponding temperature. Similarly, the instrument computes RTD temperature readings by measuring the resistance of the RTD probe and calculating temperature from the resistance value.

Since the instrument computes temperature from DCV and resistance measurements, verifying the accuracy of those DCV and resistance measurement functions guarantees the accuracy of corresponding temperature measurements. Thus, it is not necessary to perform a comprehensive temperature verification procedure if DCV and resistance verification procedures show the instrument meets its specifications in those areas. However, those who wish to verify that the Model 2002 does in fact properly display temperature can use the following procedure to do so.

Selecting the temperature sensor

Follow the steps below to select the type of temperature sensor:

1. From normal display, press CONFIG then TEMP.
2. Select SENSOR, then press ENTER.
3. Select 4-WIRE-RTD or THERMOCOUPLE as desired, then press ENTER.
4. Select the type of RTD probe or thermocouple you wish to test, then return to the CONFIG TEMPERATURE menu.
5. Select UNITS, then press ENTER.
6. Select DEG-C, then press ENTER.
7. Press EXIT as necessary to return to normal display.
8. Press the TEMP key to place the Model 2002 in the temperature display mode. Refer to further information below on how to check thermocouple and RTD probe readings.

Thermocouple temperature reading checks

To check thermocouple readings, simply apply the appropriate DC voltage listed in Table 1-11 to the Model 2002 INPUT jacks using a precision DC voltage source (such as the one used to verify DC voltage accuracy in paragraph 1.8.1), and check the displayed temperature reading. Be sure to use low-thermal cables for connections between the DC calibrator and the Model 2002 when making these tests.

NOTE

The voltages shown are based on a 0°C reference junction temperature. Use the

CONFIG-TEMP menu to set the default reference junction temperature to 0°C.

Table 1-11

Thermocouple temperature reading checks

Thermocouple type	Applied DC voltage*	Reading limits (°C) 1 year, 18°C to 28°C
J	-7.659mV 0mV 1.277mV 5.269mV 42.280mV	-190.5 to -189.5 -0.5 to +0.5 24.5 to 25.5 99.5 to 100.5 749.5 to 750.0
K	-5.730mV 0mV 1.000mV 4.096mV 54.138mV	-190.5 to -189.5 -0.5 to +0.5 24.5 to 25.5 99.5 to 100.5 1349.5 to 1350.5
T	-5.439mV 0mV 0.992mV 4.278mV 20.255mV	-190.5 to -189.5 -0.5 to +0.5 24.5 to 25.5 99.5 to 100.5 389.5 to 390.5
E	-8.561mV 0mV 1.495mV 6.319mV 75.621mV	-190.6 to -189.4 -0.6 to +0.6 24.4 to 25.6 99.4 to 100.6 989.4 to 990.6
R	0.054mV 0.647mV 4.471mV 20.877mV	7 to 13 97 to 103 497 to 503 1747 to 1753
S	0.055mV 0.646mV 4.233mV 18.503mV	7 to 13 97 to 103 497 to 503 1747 to 1753
B	0.632mV 1.241mV 4.834mV 13.591mV	355 to 365 495 to 505 995 to 1005 1795 to 1805

* Voltages shown are based on ITS-90 standard using 0°C reference junction temperature. Use CONFIG-TEMP menu to set default reference junction to 0°C.

NOTE: Reading limits shown do **not** include DCV calibrator uncertainty.

RTD temperature reading checks

Use a precision decade resistance box (see Table 1-1) to simulate probe resistances at various temperatures (Table 1-12). Be sure to use 4-wire connections between the decade resistance box and the Model 2002.

Table 1-12
RTD probe temperature reading checks

RTD probe type	Applied resistance	Reading limits (°C) 1 year, 18°C to 28°C
PT385 ($\alpha=0.00385$)	22.80 Ω	-190.068 to -189.932
	60.25 Ω	-100.021 to -99.979
	100 Ω	-0.021 to +0.021
	109.73 Ω	24.979 to 25.021
	138.50 Ω	99.979 to 100.021
	313.59 Ω	599.932 to 600.068
PT392 ($\alpha=0.00392$)	63.68 Ω	-90.021 to -89.979
	100 Ω	-0.021 to +0.021
	109.90 Ω	24.979 to 25.021
	139.16 Ω	99.979 to 100.021
	266.94 Ω	449.932 to 450.068

NOTE: Reading limits shown do **not** include uncertainty of resistance standards.

2

Calibration

2.1 Introduction

This section gives detailed procedures for calibrating the Model 2002. Basically, there are three types of calibration procedures:

- Comprehensive calibration
- AC self-calibration
- Low-level calibration

Comprehensive calibration requires accurate calibration equipment to supply precise DC voltages, DC currents, and resistance values. AC self-calibration requires no external equipment and can be performed at any time by the operator. Low-level calibration is normally performed only at the factory when the instrument is manufactured and is not usually required in the field.

NOTE

Low-level calibration is required in the field only if the Model 2002 has been repaired, or if the other calibration procedures cannot bring the instrument within stated specifications.

A single-point calibration feature is also available to allow the user to calibrate a single function or range without having to perform the entire calibration procedure.

Section 2 includes the following information:

2.2 Environmental conditions: States the temperature and humidity limits for calibration.

2.3 Warm-up period: Discusses the length of time the Model 2002 should be allowed to warm up before calibration.

2.4 Line power: States the power line voltage limits when calibrating the unit.

2.5 Calibration lock: Explains how to unlock calibration with the CAL switch.

2.6 IEEE-488 bus calibration commands: Summarizes bus commands used for calibration, lists a simple calibration program, and also discusses other important aspects of calibrating the instrument over the bus.

2.7 Calibration errors: Details front panel error messages that might occur during calibration and also explains how to check for errors over the bus.

2.8 Comprehensive calibration: Covers comprehensive (user) calibration from the front panel and over the IEEE-488 bus.

2.9 AC self-calibration: Discusses the AC user calibration process, both from the front panel and over the IEEE-488 bus.

2.10 Low-level calibration: Explains how to perform the low-level calibration procedure, which is normally required only at the factory.

2.11 Single-point calibration: Outlines the basic methods for calibrating only a single function or range instead of having to go through the entire calibration procedure.

2.2 Environmental conditions

Calibration procedures should be performed at an ambient temperature of $23^{\circ} \pm 5^{\circ}\text{C}$, and at a relative humidity of less than 80% unless otherwise noted.

NOTE

If the instrument is normally used over a different ambient temperature range, calibrate the instrument at the center of that temperature range.

If the internal temperature of the Model 2002 drifts excessively during calibration, an error will be generated. See Appendix C for additional information.

2.3 Warm-up period

The Model 2002 must be allowed to warm up for at least four hours before calibration. If the instrument has been subjected to temperature extremes (outside the range stated in paragraph 2.2), allow additional time for internal temperatures to stabilize. Typically, it takes one additional hour to stabilize a unit that is 10°C (18°F) outside the specified temperature range.

NOTE

Placement of the OPTION SLOT cover affects the internal temperature of the Model 2002. To achieve $T_{\text{CAL}} \pm 1^{\circ}\text{C}$ specifications, the OPTION SLOT cover must be in the same position (on or off) as when the Model 2002 is to be used.

The calibration equipment should also be allowed to warm up for the minimum period specified by the manufacturer.

2.4 Line power

The Model 2002 should be calibrated while operating from a line voltage in the range of 90-134V or 180-250V at 50, 60, or 400Hz.

2.5 Calibration lock

2.5.1 Comprehensive calibration lock

Before performing comprehensive calibration, you must first unlock calibration by momentarily pressing in on the recessed CAL switch. The instrument will display the following message:

CALIBRATION UNLOCKED
Calibration can now be performed

If you attempt comprehensive or low-level calibration without performing the unlocking procedure, the following message will be displayed:

CALIBRATION LOCKED
Press the CAL switch to unlock.

Note that it is not necessary to unlock calibration for the AC-only self-calibration procedure. Also, IEEE-488 bus calibration command queries such as the :DATE and :DATA commands are not protected by the calibration lock.

2.5.2 Low-level calibration lock

To unlock low-level calibration, press in and hold the CAL switch while turning on the power. Low-level calibration can then be performed.

NOTE

Do not unlock low-level calibration unless you have the appropriate equipment and intend to perform low-level calibration. See paragraph 2.10 for low-level calibration details.

2.5.3 IEEE-488 bus calibration lock status

You can determine the status of either calibration lock over the bus by using the appropriate query. To determine comprehensive calibration lock status, send the following query:

:CAL:PROT:SWIT?

The instrument will respond with the calibration lock status:

0: comprehensive calibration locked
1: comprehensive calibration unlocked

To determine the status of the low-level calibration lock, send the following query:

:CAL:PROT:LLEV:SWIT?

Responses to this calibration lock query include:

0: low-level calibration locked
1: low-level calibration unlocked

Refer to paragraph 2.6 below and Section 3 for more details on calibration commands.

2.6 IEEE-488 bus calibration commands

Table 2-1 summarizes calibration commands used to calibrate the instrument over the IEEE-488 bus (GPIB).

Table 2-1
IEEE-488 bus calibration command summary

Command	Description
:CALibration	Calibration root command.
:PROTEcted	All commands in this subsystem are protected by the CAL switch (except queries).
:INITiate	Initiate calibration.
:LOCK	Lock out calibration (opposite of enabling cal with CAL switch).
:SWITCh?	Request comprehensive CAL switch state. (0 = locked; 1 = unlocked)
:SAVE	Save cal constants to EEROM.
:DATA?	Download cal constants from 2002.
:DATE <yr>, <mon>, <day>	Send cal date to 2002.
:DATE?	Request cal date from 2002.
:NDUE <yr>, <mon>, <day>	Send next due cal date to 2002.
:NDUE?	Request next due cal date from 2002.
:DC	Comprehensive calibration subsystem.
:ZERO	Short-circuit calibration step.
:V2 <Nrf>	+2V DC calibration step.
:V20 <Nrf>	+20V DC calibration step.
:OHM1M <Nrf>	1M Ω calibration step.
:OHM200K <Nrf>	200k Ω calibration step.
:OHM20K <Nrf>	20k Ω calibration step.
:OHM2K <Nrf>	2k Ω calibration step.
:OHM200 <Nrf>	200 Ω calibration step.
:OHM20 <Nrf>	20 Ω calibration step.
:A200U <Nrf>	200 μ A DC calibration step.
:A2M <Nrf>	2mA DC calibration step.
:A20M <Nrf>	20mA DC calibration step.
:A200M <Nrf>	200mA DC calibration step.
:A2 <Nrf>	2A DC calibration step.
:OPEN	Open circuit calibration step.
:LLEVEl	Low-level calibration subsystem.
:SWITCh?	Request low-level CAL switch state. (0 = locked; 1 = unlocked)
:STEP <Step #>	
1	20V AC at 1kHz step.
2	20V AC at 30kHz step.
3	200V AC at 1kHz step.
4	200V AC at 30kHz
5	1.5V AC at 1kHz step.
6	200mV AC at 1kHz step.
7	5mV AC at 100kHz step.
8	0.5mV AC at 1kHz step.
9	+100V DC step.
10	-20V DC step.
11	Rear inputs short-circuit step.
12	20mA AC at 1kHz step.
13	2V AC at 1Hz step.
:UNPROTEcted	Commands in this subsystem not protected by CAL switch.
:ACCompensation	Perform user AC calibration (disconnect all cables)

NOTE: Upper-case letters indicate short form of each command. For example, instead of sending ":CALibration:PROTEcted:INITiate", send ":CAL:PROT:INIT".

2.7 Calibration errors

The Model 2002 checks for errors after each calibration step, minimizing the possibility that improper calibration may occur due to operator error. The following paragraphs discuss both front panel and bus error reporting.

2.7.1 Front panel error reporting

If an error is detected during comprehensive calibration, the instrument will display an appropriate error message (see Appendix C).

2.7.2 IEEE-488 bus error reporting

You can detect errors over the bus by testing the state of EAV (Error Available) bit (bit 2) in the status byte. (Use the *STB? query or serial polling to request the status byte.) If you wish to generate an SRQ (Service Request) on errors, send "*SRE 4" to the instrument to enable SRQ on errors.

You can query the instrument for the type of error by using the ":SYSTem:ERRor?" query. The Model 2002 will respond with the error number and a text message describing the nature of the error. Appendix C summarizes calibration errors.

2.8 Comprehensive calibration

The comprehensive calibration procedure calibrates the DCV, DCI, and ohms functions. At the end of the front panel calibration procedure, AC self-calibration is also performed to complete the calibration process.

Comprehensive calibration should be performed at least once a year, or every 90 days to ensure the unit meets the corresponding specifications.

The comprehensive calibration procedure covered in this paragraph is normally the only calibration required in the field. However, if the unit has been repaired, you should perform the low-level calibration procedure explained in paragraph 2.10.

2.8.1 Recommended equipment for comprehensive calibration

Table 2-2 lists all test equipment recommended for comprehensive calibration. Alternate equipment (such as a DC transfer standard and characterized resistors) may be used as long as that equipment has specifications at least as good as those listed in the table.

Table 2-2
Recommended equipment for comprehensive calibration

Mfg.	Model	Description	Specifications*
Fluke	5700A	Calibrator	<p>±5ppm basic uncertainty.</p> <p>DC Voltage: 2V: ±7ppm 20V: ±5ppm</p> <p>Resistance: 19Ω: ±26ppm 190Ω: ±17ppm 1.9kΩ: ±11ppm 19kΩ: ±11ppm 100kΩ: ±13ppm 1MΩ: ±18ppm</p> <p>DC Current: 200μA: ±100ppm 2mA: ±55ppm 20mA: ±55ppm 200mA: ±65ppm 1A: ±110ppm</p>
Keithley	8610	Low-thermal shorting plug	

* 90-day calibrator specifications shown include total uncertainty at specified output.

2.8.2 Front panel comprehensive calibration

Follow the steps below to calibrate the Model 2002 from the front panel. Refer to paragraph 2.8.3 below for the procedure to calibrate the unit over the IEEE-488 bus. Table 2-3 summarizes the front panel calibration procedure.

Table 2-3
Front panel comprehensive calibration summary

Step	Description	Equipment/connections
1	Warm-up, unlock calibration	None
2	DC Zero calibration	Low-thermal short
3	+2V DC calibration	DCV calibrator
4	+20V DC calibration	DCV calibrator
5	1M Ω calibration	Ohms calibrator
6	200k Ω calibration	Ohms calibrator
7	20k Ω calibration	Ohms calibrator
8	2k Ω calibration	Ohms calibrator
9	200 Ω calibration	Ohms calibrator
10	20 Ω calibration	Ohms calibrator
11	200 μ A DC calibration	DCA calibrator
12	2mA DC calibration	DCA calibrator
13	20mA DC calibration	DCA calibrator
14	200mA DC calibration	DCA calibrator
15	2A DC calibration	DCA calibrator
16	Open-circuit calibration	Disconnect leads
17	AC self-calibration	Disconnect leads
18	Enter calibration dates	None
19	Save calibration constants	None

Procedure

Step 1: Prepare the Model 2002 for calibration

1. Turn on the power, and allow the Model 2002 to warm up for at least four hours before performing calibration.
2. Unlock comprehensive calibration by briefly pressing in on the recessed front panel CAL switch, and verify that the following message is displayed:

CALIBRATION UNLOCKED
 Calibration can now be performed

3. Enter the front panel calibration menu as follows:
 - A. From normal display, press MENU.
 - B. Select CALIBRATION, and press ENTER.
 - C. Select COMPREHENSIVE, then press ENTER.
4. At this point, the instrument will display the following message:

DC CALIBRATION PHASE

Step 2: DC zero calibration

1. Press ENTER. The instrument will display the following prompt.

SHORT CIRCUIT INPUTS

2. Connect the Model 8610 low-thermal short to the instrument INPUT and SENSE terminals, as shown in Figure 2-1. Wait at least three minutes before proceeding to allow for thermal equilibrium.

NOTE

Be sure to connect the low-thermal short properly to the HI, LO, and SENSE terminals. Keep drafts away from low-thermal connections to avoid thermal drift, which could affect calibration accuracy.

3. Press ENTER. The instrument will then begin DC zero calibration. While calibration is in progress, the following will be displayed:

Performing Short Ckt Calibration

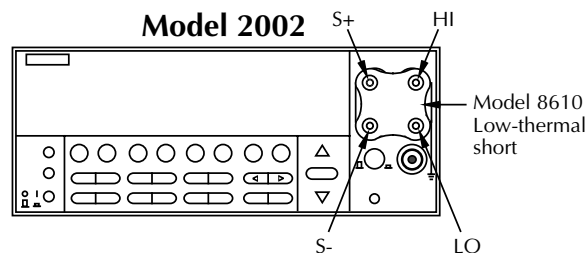

Figure 2-1
Low-thermal short connections

Step 3: DC volts calibration

1. When the DC zero calibration step is completed, the following message will be displayed:

CONNECT 2 VDC

2. Disconnect the low-thermal short, and connect the DC calibrator to the INPUT jacks, as shown in Figure 2-2.

NOTE

Although 4-wire connections are shown, the sense leads are connected and disconnected at various points in the procedure by turning calibrator external sense on or off as appropriate. If your calibrator does not have provisions for turning external sense on and off, disconnect the sense leads when external sensing is to be turned off, and connect the sense leads when external sensing is to be turned on.

3. Set the calibrator output to +2.000000V, and turn external sense off. Wait at least three minutes for thermal equilibrium.
4. Press ENTER, and note that the Model 2002 displays the presently selected calibration voltage:

INPUT = 2.00000000 V

(At this point, you can use the cursor and range keys to set the calibration voltage to a value from 0.95 to 2.05V if your calibrator cannot source 2V.)

NOTE

For best results, it is recommended that you use the stated calibration values throughout the procedure whenever possible.

5. Press ENTER. The instrument will display the following during calibration:

Performing 2 VDC Calibration

6. After completing 2VDC calibration, the instrument will display the following:

CONNECT 20 VDC

7. Set the DC calibrator output to +20.000000V.
8. Press ENTER, and note that the instrument displays the calibration voltage:

INPUT = 20.0000000

(At this point, you can use the cursor and range keys to set the calibration voltage to a value from 9.5 to 20.5V if your calibrator cannot source 20V.)

9. Press ENTER. The instrument will display the following message to indicate it is performing 20V DC calibration:

Performing 20 VDC Calibration

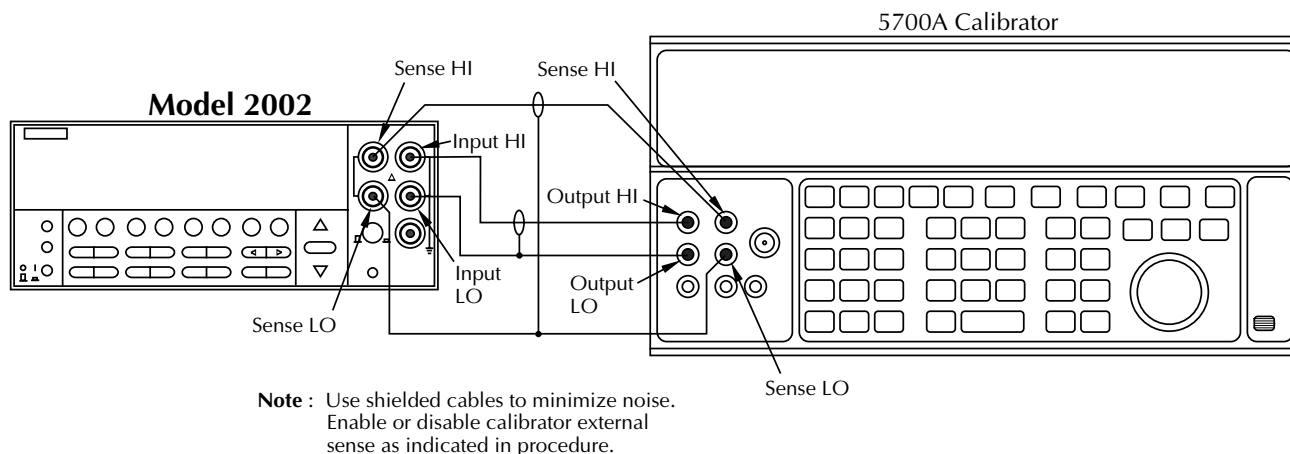

Figure 2-2
Calibrator connections for DC volts and ohms portion of comprehensive calibration

Step 5: Ohms calibration

1. After completing 20VDC calibration, the instrument will display the following:

CONNECT 1 MΩ 4W

2. Set the calibrator output to 1.00000MΩ, and make sure that external sense is turned on.

NOTE

Use external sensing (4-wire ohms) when calibrating all resistance ranges. Be sure that the calibrator external sense mode is on.

3. Press ENTER, and note that the Model 2002 displays the resistance calibration value:

INPUT = 1.0000000 MΩ

4. Using the cursor and range keys, set the resistance value displayed by the Model 2002 to the exact resistance value displayed by the calibrator. (The allowable range is from 475kΩ to 1.025MΩ.)
5. Press ENTER, and note that the instrument displays the following during 1MΩ calibration:

Performing 1 MΩ Calibration

6. After completing 1MΩ calibration, the instrument will display the following:

CONNECT 100 kΩ 4W

7. Set the calibrator output to 100kΩ, and make sure that external sense is turned on.
8. Press ENTER, and note that the Model 2002 displays the resistance calibration value:

INPUT = 100.00000 kΩ

9. Using the cursor and range keys, set the resistance value displayed by the Model 2002 to the exact resistance value displayed by the calibrator. (The allowable range for this parameter is from 95kΩ to 205kΩ.)

10. Press ENTER to complete the 200kΩ calibration step.
11. Repeat steps 7 through 10 for the 20kΩ, 2kΩ, 200Ω, and 20Ω ranges in that order. Be sure to set the calibrator to the correct resistance value, and adjust the Model 2002 display to agree with the calibrator value.

Calibration step	Calibration value*	Allowable range
2MΩ	1MΩ	475kΩ to 1.025MΩ
200kΩ	100kΩ	95kΩ to 205kΩ
20kΩ	19kΩ	9.5kΩ to 20.5kΩ
2kΩ	1.9kΩ	0.95kΩ to 2.05kΩ
200Ω	190Ω	95Ω to 205Ω
20Ω	19Ω	9.5Ω to 20.5Ω

* Nominal values shown. Use exact calibrator value.

Step 6: DC amps calibration

1. After ohms calibration is completed, the instrument will prompt you for the first DC amps calibration step:

CONNECT 200 μADC

2. Connect the DC amps calibrator to the AMPS and INPUT LO terminals (see Figure 2-3).
3. Set the calibrator output to 200.000μA, and make sure the unit is in operate. (The allowable range is from 95μA to 205μA.)
4. Be sure that the displayed current matches the calibration value, then press ENTER to complete this calibration step.
5. Repeat steps 3 and 4 for the remaining amps calibration points as follows:

Calibration step	Calibration current	Allowable range
200μA	200.000μA	95μA to 205μA
2mA	2.00000mA	0.95mA to 2.05mA
20mA	20.00000mA	9.5mA to 20.5mA
200mA	200.00000mA	95mA to 205mA
2A	1.00000A	0.95A to 2.05A

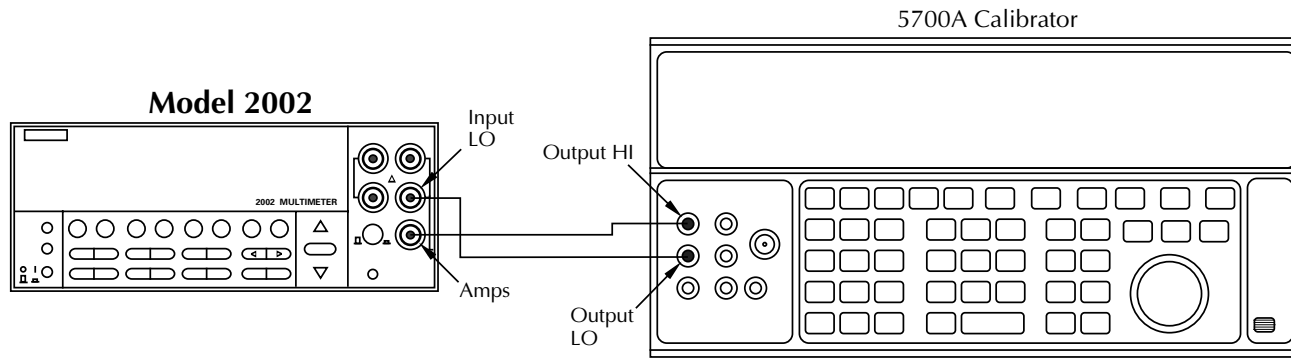

Note: Be sure calibrator is set for normal current output.

Figure 2-3
Connections for amps comprehensive calibration

Step 7: Open-circuit calibration

1. At this point, the instrument will display the following message advising you to disconnect test leads:

OPEN CIRCUIT INPUTS

2. Disconnect all test leads from the INPUT and AMPS jacks, then press ENTER. During this calibration phase, the instrument will display the following:

Performing Open Ckt Calibration

Step 8: AC self-calibration

1. After open-circuit calibration, the instrument will display the following message:

AC CALIBRATION PHASE

2. Make sure all test leads are still disconnected from the Model 2002 INPUT and SENSE jacks.
3. Press ENTER to perform AC calibration, which will take about six minutes to complete. During AC calibration, the instrument will display the following:

Calibrating AC: Please wait

4. When AC calibration is finished, the instrument will display the following:

AC CAL COMPLETE

Step 9: Enter calibration dates

1. Press ENTER, and note that the instrument prompts you to enter the present calibration date:

CAL DATE: 01/01/94

2. Use the cursor and range keys to enter the current date as the calibration date, then press ENTER. Press ENTER again to confirm the date as being correct.
3. The instrument will then prompt you to enter the due date for next calibration:

NEXT CAL: 01/01/95

4. Use the cursor and range keys to set the date as desired, then press ENTER. Press ENTER a second time to confirm your selection.

Step 10: Save calibration constants

1. At the end of a successful calibration cycle, the instrument will display the following:

CALIBRATION COMPLETE

2. If you wish to save calibration constants from the procedure just completed, press ENTER. Assuming the calibration was successful, the unit will display the following:

CALIBRATION SUCCESS

3. If you do not want to save calibration constants from the procedure just completed and wish instead to restore previous constants, cycle power to the unit.
4. Press EXIT to return to normal display after calibration.

NOTE

Valid calibration constants will be saved, and comprehensive calibration will be automatically locked out after the calibration procedure has been completed.

2.8.3 IEEE-488 bus comprehensive calibration

Follow the procedure outlined below to perform comprehensive calibration over the IEEE-488 bus. Table 2-4 summarizes the calibration procedure and bus commands. See Appendix B for example calibration programs.

Table 2-4
IEEE-488 bus comprehensive calibration summary

Step	Description	IEEE-488 bus command*
1	Warm-up, unlock calibration	
2	Initiate calibration	:CAL:PROT:INIT
3	DC Zero calibration	:CAL:PROT:DC:ZERO
4	+2VDC calibration	:CAL:PROT:DC:V2 2
5	+20VDC calibration	:CAL:PROT:DC:V20 20
6	1M Ω calibration	:CAL:PROT:DC:OHM1M 1E6
7	200k Ω calibration	:CAL:PROT:DC:OHM200K 100E3
8	20k Ω calibration	:CAL:PROT:DC:OHM20K 19E3
9	2k Ω calibration	:CAL:PROT:DC:OHM2K 1.9E3
10	200 Ω calibration	:CAL:PROT:DC:OHM200 190
11	20 Ω calibration	:CAL:PROT:DC:OHM20 19
12	200 μ A calibration	:CAL:PROT:DC:A200U 200E-6
13	2mA calibration	:CAL:PROT:DC:A2M 2E-3
14	20mA calibration	:CAL:PROT:DC:A20M 20E-3
15	200mA calibration	:CAL:PROT:DC:A200M 200E-3
16	2A calibration	:CAL:PROT:DC:A2 1
17	Open-circuit calibration	:CAL:PROT:DC:OPEN
18	Perform user AC cal	:CAL:UNPR:ACC
19	Save calibration dates	:CAL:PROT:DATE <yr>, <mon>, <day> :CAL:PROT:NDUE <yr>, <mon>, <day>
20	Save calibration constants	:CAL:PROT:DC:SAVE
21	Lock out calibration	:CAL:PROT:LOCK

* For resistance calibration points, use exact calibrator value for command parameter instead of nominal parameter shown.

Procedure

Step 1: Prepare the Model 2002 for calibration

1. Connect the Model 2002 to the IEEE-488 bus of the computer using a shielded IEEE-488 cable such as the Keithley Model 7007.
2. Turn on the power, and allow the Model 2002 to warm up for at least four hours before performing calibration.
3. Unlock calibration by briefly pressing in on the recessed front panel CAL switch, and verify that the following message is displayed:

CALIBRATION UNLOCKED

Calibration can now be performed

NOTE

You can query the instrument for the state of the comprehensive CAL switch by using the following query:

:CAL:PROT:SWIT?

A returned value of 0 indicates that calibration is locked, while a returned value of 1 shows that calibration is unlocked.

4. Make sure the primary address of the Model 2002 is the same as the address specified in the program you will be using to send commands.
5. Send the following command over the bus to initiate calibration:

:CAL:PROT:INIT

Step 2: DC zero calibration

1. Connect the Model 8610 low-thermal short to the instrument INPUT and SENSE terminals, as shown in Figure 2-1. Wait at least three minutes before proceeding to allow for thermal equilibrium.

NOTE

Be sure to properly connect HI, LO, and SENSE terminals. Keep drafts away from low-thermal connections to avoid thermal drift, which could affect calibration accuracy.

2. Send the following command over the bus:

:CAL:PROT:DC:ZERO

3. Wait until the Model 2002 finishes this calibration step before proceeding. (You can use the *OPC or *OPC? commands to determine when calibration steps end, as discussed in paragraph 3.6 in Section 3.)

Step 3: DC Volts Calibration

1. Disconnect the low-thermal short, and connect the DC calibrator to the INPUT jacks, as shown in Figure 2-2.

NOTE

Although 4-wire connections are shown, the sense leads are connected and disconnected at various points in the procedure by turning calibrator external sense on or off as appropriate. If your calibrator does not have provisions for turning external sense on and off, disconnect the sense leads when external sensing is to be turned off, and connect the sense leads when external sensing is to be turned on.

2. Set the DC calibrator output to +2.00000V, and turn external sense off. Wait at least three minutes for thermal equilibrium.
3. Send the following command to the Model 2002 over the IEEE-488 bus:

:CAL:PROT:DC:V2 2

(Be sure to use the exact calibration value as the command parameter if you are using a voltage other than 2V. The allowable range from is 0.95V to 2.05V.)

NOTE

For best results, use the calibration values given in this procedure whenever possible.

4. Wait until the Model 2002 finishes this step before going on.

NOTE

You can check for errors after each calibration step by sending the :SYST:ERR? query to the instrument. See paragraph 2.7.2.

5. Set the DC calibrator output to +20.00000V.
6. Send the following command to the instrument:

:CAL:PROT:DC:V20 20

(Send the actual calibration value in the range of 9.5V to 20.5V if you are using a different voltage.)

7. Wait until the Model 2002 finishes this step before going on.

Step 4: Ohms calibration

1. Set the calibrator output to 1MΩ, and turn external sense on.

NOTE

External sensing (4-wire ohms) should be used when calibrating all resistance ranges.

2. Send the following command to the Model 2002:

```
:CAL:PROT:DC:OHM1M <value>
```

Here, <value> is the actual calibrator resistance value. For example, if the calibrator resistance is 1.002MΩ, the command would appear as follows:

```
:CAL:PROT:DC:OHM1M 1.002E6
```

(The allowable range for this parameter is from 475E3 to 1.025E6.)

3. Wait until the Model 2002 finishes 1MΩ calibration before continuing.
4. Set the calibrator resistance to 100kΩ, and make sure external sense is still turned on.

5. Repeat steps 2 and 3 for each of the remaining ohms calibration points as shown in Table 2-5.

Step 5: Amps calibration

1. Connect the calibrator to the AMPS and INPUT LO jacks, as shown in Figure 2-3.
2. Set the calibrator output to 200.000μA, and place the unit in operate.
3. Send the following command to the Model 2002:

```
:CAL:PROT:DC:A200U 200E-6
```

If you are using a different calibration value, be sure to substitute that value for the parameter shown above. (The allowable range is from 95μA to 205μA.)

Wait for the instrument to complete this step before continuing.

4. Repeat steps 2 and 3 for the remaining amps calibration points shown in Table 2-6.

Step 6. Open-circuit calibration

1. Disconnect all test leads from the Model 2002 INPUT and AMPS jacks.
2. Send the following command to the instrument:

```
:CAL:PROT:DC:OPEN
```

3. Wait until open-circuit calibration is complete before going on to the next step.

Table 2-5
Ohms calibration summary

Cal point	Nominal resistance	Allowable range	Command*
2MΩ	1MΩ	475kΩ to 1.025MΩ	:CAL:PROT:DC:OHM1M 1E6
200kΩ	100kΩ	95kΩ to 205kΩ	:CAL:PROT:DC:OHM200K 100E3
20kΩ	19kΩ	9.5kΩ to 20.5kΩ	:CAL:PROT:DC:OHM20K 19E3
2kΩ	1.9kΩ	0.95kΩ to 2.05kΩ	:CAL:PROT:DC:OHM2K 1.9E3
200Ω	190Ω	95Ω to 205Ω	:CAL:PROT:DC:OHM200 190
20Ω	19Ω	9.5Ω to 20.5Ω	:CAL:PROT:DC:OHM20 19

* Nominal resistance values shown. Use exact calibrator resistance value for command parameter.

Table 2-6
Amps calibration summary

Cal point	Calibrator current	Allowable range	Calibration command
200 μ A	200.000 μ A	95 μ A to 205 μ A	:CAL:PROT:DC:A200U 200E-6
2mA	2.00000mA	0.95mA to 2.05mA	:CAL:PROT:DC:A2M 2E-3
20mA	20.0000mA	9.5mA to 20.5mA	:CAL:PROT:DC:A20M 20E-3
200mA	200.000mA	95mA to 205mA	:CAL:PROT:DC:A200M 200E-3
2A	1.00000A	0.95A to 2.05A	:CAL:PROT:DC:A2 1

Step 7: Perform AC user calibration

To perform user AC calibration, send the following command:

```
:CAL:UNPR:ACC
```

Note that AC calibration will take about six minutes to complete.

Step 8: Enter calibration dates

To set the calibration date and next due date, use the following commands to do so:

```
:CAL:PROT:DATE <yr>, <mon>, <day>
```

```
:CAL:PROT:NDUE <yr>, <mon>, <day>
```

Where <yr>, <mon>, and <day> are the year, month, and date and must be separated by commas.

Step 9: Save calibration constants

Calibration is now complete, so you can store the calibration constants in EEROM by sending the following command:

```
:CAL:PROT:SAVE
```

Step 10: Lock out calibration

To lock out further calibration, send the following command after completing the calibration procedure:

```
:CAL:PROT:LOCK
```

2.9 AC self-calibration

The AC self-calibration procedure requires no external equipment and can be performed at any time by the user. As

the name implies, this calibration procedure assures the accuracy of ACI and ACV measurements.

NOTE

The AC calibration constants generated by this procedure are not permanently stored. Thus, AC calibration constants are in effect only until the power is turned off. In order to permanently store AC calibration constants, you must perform the comprehensive or low-level calibration procedure and then choose to save calibration constants at the end of that procedure. See paragraph 2.8 or 2.10 for details.

2.9.1 Front panel AC calibration

Procedure:

1. Disconnect all test leads or cables from the INPUT and SENSE jacks.
2. Press MENU. The instrument will display the following:

```
MAIN MENU
SAVESETUP GPIB CALIBRATION
```

3. Select CALIBRATION, then press ENTER. The Model 2002 will display the following:

```
PERFORM CALIBRATION
COMPREHENSIVE POINT-CALS
```

4. Select POINT-CALS, then press ENTER. The instrument will then display the following:

```
POINT CALIBRATION
AC-CAL DCV OHMS DCI
```

5. Select AC-CAL, then press ENTER. The instrument will display the following message:

AC CALIBRATION PHASE

Disconnect inputs; press ENTER

6. Press ENTER to begin AC calibration, which will take about six minutes to complete. During AC calibration, the instrument will display the following:

Calibrating AC: Please wait

7. Once the process has been successfully completed, the message below will be displayed, and you can press ENTER or EXIT to return to normal display:

AC CAL COMPLETE

Press ENTER or EXIT to continue.

2.9.2 IEEE-488 bus AC self-calibration**Procedure:**

1. Disconnect all test leads and cables from the INPUT and SENSE jacks.
2. Send the following command over the bus: ":CAL:UNPR:ACC".
3. Wait until calibration has been completed before sending any further commands (about six minutes).
4. Check for calibration errors by using the :SYST:ERR? query.

2.10 Low-level calibration

Low-level calibration is normally performed only at the factory when the instrument is manufactured and is not usually required in the field. The following paragraphs give detailed procedures for performing low-level calibration should it ever become necessary in the field.

NOTE

Low-level calibration is required in the field only if the Model 2002 has been repaired, or if the other calibration procedures cannot bring the instrument within stated specifications. The low-level calibration procedure includes the comprehensive calibration steps discussed in paragraph 2.8.

2.10.1 Recommended equipment for low-level calibration

Table 2-7 summarizes recommended equipment for low-level calibration. Alternate equipment may be used as long as corresponding specifications are at least as good as those listed in the table.

2.10.2 Low-level calibration summary

Table 2-8 summarizes the steps necessary to complete the low-level calibration procedure. The procedure should be performed in the order shown in the table. Calibration commands shown are to be used when calibrating the unit over the IEEE-488 bus.

WARNING

Some low-level calibration steps require the use of hazardous voltages.

See Appendix B for example calibration programs.

Table 2-7
Recommended equipment for low-level calibration

Mfg.	Model	Description	Specifications*
Fluke	5700A	Calibrator	<p>±5ppm basic uncertainty.</p> <p>DC Voltage: ±2V: ±7ppm +20V: ±5ppm +100V: ±7ppm</p> <p>Resistance: 19Ω: ±26ppm 190Ω: ±17ppm 1.9kΩ: ±11ppm 19kΩ: ±11ppm 100kΩ: ±13ppm 1MΩ: ±18ppm</p> <p>DC Current: 200μA: ±100ppm 2mA: ±55ppm 20mA: ±55ppm 200mA: ±65ppm 1A: ±110ppm</p> <p>AC Voltage: 0.5mV @ 1kHz: ±10000ppm 5mV @ 100kHz: ±2400ppm 200mV @ 1kHz: ±150ppm 1.5V @ 1kHz: ±80ppm 20V @ 1kHz: ±80ppm 20V @ 30kHz: ±140ppm 200V @ 1kHz: ±85ppm 200V @ 30kHz: ±240ppm</p> <p>AC Current: 20mA @ 1kHz: ±160ppm</p>
Keithley	3930A or 3940	Synthesizer	2V rms @ 1Hz
Keithley	8610	Low-thermal shorting plug	

* 90-day calibrator specifications shown include total uncertainty at specified output.

Table 2-8
Low-level calibration summary

Calibration signal	Calibration command*	Comments
None	:CAL:PROT:INIT	Initiate calibration.
Low-thermal short	:CAL:PROT:DC:ZERO	Comprehensive cal zero.
2V DC	:CAL:PROT:DC:V2	Comprehensive cal 2V.
20V DC	:CAL:PROT:DC:V20	Comprehensive cal 20V.
1M Ω	:CAL:PROT:DC:OHM1M 1E6	Comprehensive cal 1M Ω .
100k Ω	:CAL:PROT:DC:OHM200K 100E3	Comprehensive cal 200k Ω .
19k Ω	:CAL:PROT:DC:OHM20K 19E3	Comprehensive cal 20k Ω .
1.9k Ω	:CAL:PROT:DC:OHM2K 1.9E3	Comprehensive cal 2k Ω .
190 Ω	:CAL:PROT:DC:OHM200 190	Comprehensive cal 200 Ω .
19 Ω	:CAL:PROT:DC:OHM20 19	Comprehensive cal 20 Ω .
200 μ A DC	:CAL:PROT:DC:A200U 200E-6	Comprehensive cal 200 μ A.
2mA DC	:CAL:PROT:DC:A2M 2E-3	Comprehensive cal 2mA.
20mA DC	:CAL:PROT:DC:A20M 20E-3	Comprehensive cal 20mA.
200mA DC	:CAL:PROT:DC:A200M 200E-3	Comprehensive cal 200mA.
1A DC	:CAL:PROT:DC:A2 1	Comprehensive cal 2A.
Disconnect leads	:CAL:PROT:DC:OPEN	Comprehensive cal open.
None	:CAL:UNPR:ACC	AC user calibration.
20V AC @ 1kHz	:CAL:PROT:LLEV:STEP 1	Low-level Step 1.
20V AC @ 30kHz	:CAL:PROT:LLEV:STEP 2	Low-level Step 2.
200V AC @ 1kHz	:CAL:PROT:LLEV:STEP 3	Low-level Step 3.
200V AC @ 30kHz	:CAL:PROT:LLEV:STEP 4	Low-level Step 4.
1.5V AC @ 1kHz	:CAL:PROT:LLEV:STEP 5	Low-level Step 5.
200mV AC @ 1kHz	:CAL:PROT:LLEV:STEP 6	Low-level Step 6.
5mV AC @ 100kHz	:CAL:PROT:LLEV:STEP 7	Low-level Step 7.
0.5mV AC @ 1kHz	:CAL:PROT:LLEV:STEP 8	Low-level Step 8.
+100V DC	:CAL:PROT:LLEV:STEP 9	Low-level Step 9.
-20V DC	:CAL:PROT:LLEV:STEP 10	Low-level Step 10.
Rear short circuit	:CAL:PROT:LLEV:STEP 11	Low-level Step 11.
20mA AC @ 1kHz	:CAL:PROT:LLEV:STEP 12	Low-level Step 12.
2V rms @ 1Hz	:CAL:PROT:LLEV:STEP 13	Low-level Step 13.
None	:CAL:PROT:DATE <yr>, <mon>, <day>	Program cal date.
None	:CAL:PROT:NDUE <yr>, <mon>, <day>	Program cal due date.
None	:CAL:PROT:SAVE	Save constants.
None	:CAL:PROT:LOCK	Lock out calibration.

* Parameters shown for resistance calibration points are nominal values. Use actual calibration value for command parameter.

2.10.3 Front panel low-level calibration procedure

Procedure

Step 1: Prepare the Model 2002 for calibration

1. Turn off the power if the instrument is presently turned on.
2. While pressing in on the recessed CAL switch, turn on the power. (Holding in the CAL switch while turning on the power enables low-level calibration.)
3. Allow the Model 2002 to warm up for at least four hours before performing calibration.
4. Press the MENU key. The instrument will display the following:

```
MAIN MENU
SAVESETUP GPIB CALIBRATION
```

5. Select CALIBRATION, then press ENTER. The Model 2002 will display the following:

```
PERFORM CALIBRATION
COMPREHENSIVE POINT-CALS
```

6. Select COMPREHENSIVE, then press ENTER. The instrument will display the following:

```
DC CALIBRATION PHASE
```

Step 2: DC zero calibration

1. Press ENTER. The instrument will display the following prompt:

```
SHORT CIRCUIT INPUTS
```

2. Connect the Model 8610 low-thermal short to the instrument INPUT and SENSE terminals, as shown in Figure 2-1. Wait at least three minutes before proceeding to allow for thermal equilibrium.

NOTE

Be sure to connect the low-thermal short properly to the HI, LO, and SENSE terminals. Keep drafts away from low-thermal connections to avoid thermal drift, which could affect calibration accuracy.

3. Press ENTER. The instrument will then begin DC zero calibration. While calibration is in progress, the following will be displayed:

```
Performing Short Ckt Calibration
```

Step 3: DC volts calibration

1. When the DC zero calibration step is completed, the following message will be displayed:

```
CONNECT 2 VDC
```

2. Disconnect the low-thermal short, and connect the DC calibrator to the INPUT jacks, as shown in Figure 2-2.

NOTE

Although 4-wire connections are shown, the sense leads are connected and disconnected at various points in the procedure by turning calibrator external sense on or off as appropriate. If your calibrator does not have provisions for turning external sense on and off, disconnect the sense leads when external sensing is to be turned off, and connect the sense leads when external sensing is to be turned on.

3. Set the calibrator output to +2.00000V, and turn external sense off. Wait at least three minutes for thermal equilibrium.
4. Press ENTER, and note that the Model 2002 displays the presently selected calibration voltage:

```
INPUT = 2.00000000 V
```

(At this point, you can use the cursor and range keys to set the calibration voltage to a value from 0.95 to 2.05V if your calibrator cannot source 2V.)

NOTE

For best results, it is recommended that you use the stated calibration values throughout the procedure whenever possible.

5. Press ENTER. The instrument will display the following during calibration:

```
Performing 2 VDC Calibration
```

6. After completing 2VDC calibration, the instrument will display the following:

```
CONNECT 20 VDC
```

7. Set the DC calibrator output to +20.000000V.
8. Press ENTER, and note that the instrument displays the calibration voltage:

INPUT = 20.0000000 V

(At this point, you can use the cursor and range keys to set the calibration voltage to a value from 9.5 to 20.5V if your calibrator cannot source 20V.)

9. Press ENTER. The instrument will display the following message to indicate it is performing 20V DC calibration:

Performing 20 VDC Calibration

Step 5: Ohms calibration

1. After completing 20VDC calibration, the instrument will display the following:

CONNECT 1 MΩ 4W

2. Set the calibrator output to 1.00000MΩ, and make sure that external sense is turned on.

NOTE

Be sure that the calibrator external sense mode is turned on when calibrating all resistance ranges.

3. Press ENTER, and note that the Model 2002 displays the resistance calibration value:

INPUT = 1.0000000 MΩ

4. Using the cursor and range keys, set the resistance value displayed by the Model 2002 to the exact resistance value displayed by the calibrator. (The allowable range is from 475kΩ to 1.025MΩ.)
5. Press ENTER, and note that the instrument displays the following during 1MΩ calibration:

Performing 1 MΩ Calibration

6. After completing 1MΩ calibration, the instrument will display the following:

CONNECT 100 kΩ 4W

7. Set the calibrator output to 100kΩ, and make sure that external sense is turned on.
8. Press ENTER, and note that the Model 2002 displays the resistance calibration value:

INPUT = 100.00000 kΩ

9. Using the cursor and range keys, set the resistance value displayed by the Model 2002 to the exact resistance value displayed by the calibrator. (The allowable range for this parameter is from 95kΩ to 205kΩ.)
10. Press ENTER to complete the 200kΩ calibration step.
11. Repeat steps 7 through 10 for the 20kΩ, 2kΩ, 200Ω, and 20Ω ranges in that order. Be sure the set the calibrator and Model 2002 to the correct resistance value as follows:

Calibration step	Calibration value*	Allowable range
2MΩ	1MΩ	475kΩ to 1.025MΩ
200kΩ	100kΩ	95kΩ to 205kΩ
20kΩ	19kΩ	9.5kΩ to 20.5kΩ
2kΩ	1.9kΩ	0.95kΩ to 2.05kΩ
200Ω	190Ω	95Ω to 205Ω
20Ω	19Ω	9.5Ω to 20.5Ω

* Nominal values shown. Use exact calibrator value.

Step 6: DC amps calibration

1. After ohms calibration is completed, the instrument will prompt you for the first DC amps calibration step:

CONNECT 200 μADC

2. Connect the DC amps calibrator to the AMPS and INPUT LO terminals (see Figure 2-3).
3. Set the calibrator output to 200.000μA, and make sure the unit is in operate. (The allowable range is from 95μA to 205μA.)
4. Be sure that the displayed current matches the calibration value, then press ENTER to complete this calibration step.
5. Repeat steps 3 and 4 for the remaining amps calibration points as follows:

Calibration step	Calibrator current	Allowed range
200μA	200.000μA	95μA to 205μA
2mA	2.00000mA	0.95mA to 2.05mA
20mA	20.00000mA	9.5mA to 20.5mA
200mA	200.00000mA	95mA to 205mA
2A	1.00000A	0.95A to 2.05A

Step 7: Open-circuit calibration

1. At this point, the instrument will display the following message advising you to disconnect test leads:

OPEN CIRCUIT INPUTS

2. Disconnect all test leads from the INPUT and AMPS jacks, then press ENTER. During this calibration phase, the instrument will display the following:

Performing Open Ckt Calibration

Step 8: AC self-calibration

1. After open circuit calibration, the instrument will display the following message:

AC CALIBRATION PHASE

2. Make sure all test leads are still disconnected from the Model 2002 INPUT and SENSE jacks.
3. Press ENTER to perform AC calibration, which will take about six minutes to complete. During AC calibration, the instrument will display the following:

Calibrating AC: Please wait

4. When AC calibration is finished, the instrument will display the following:

AC CAL COMPLETE

Step 9: Low-level calibration steps

1. Press ENTER. The instrument will display the following to indicate the start of the low-level calibration phase:

LOW-LEVEL CAL PHASE

NOTE

Use the exact calibration values shown when performing the following steps.

2. Connect the calibrator to the INPUT terminals, as shown in Figure 2-4.
3. Press ENTER. The instrument will display the following:

Connect 20V @ 1kHz

4. Set the calibrator to output 20V AC at a frequency of 1kHz, then press ENTER. The instrument will display the following:

Low-Level Cal - Step 1 of 13

5. Next, the instrument will prompt for a new calibration signal:

Connect 20V @ 30kHz

6. Program the calibrator for an output voltage of 20V AC at 30kHz, then press ENTER. The instrument will display the following while calibrating this step:

Low-Level Cal - Step 2 of 13

7. The Model 2002 will then display:

Connect 200V @ 1kHz

8. Set the calibrator output to 200V AC at a frequency of 1kHz, then press ENTER. The Model 2002 will display the following message:

Low-Level Cal - Step 3 of 13

9. When finished with this step, the Model 2002 will display:

Connect 200V @ 30kHz

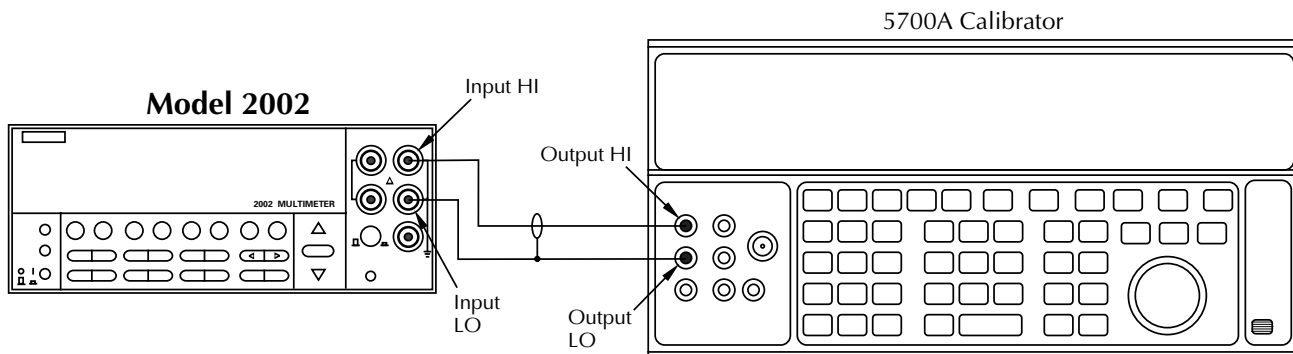

Figure 2-4
Calibrator voltage connections

10. Set the calibrator output to 200V AC at 30kHz, then press ENTER. The Model 2002 will display the following:
Low-Level Cal - Step 4 of 13
11. The unit will then prompt for the next calibration signal:
Connect 1.5V @ 1kHz
12. Set the calibrator for 1.5V AC at a frequency of 1kHz. The Model 2002 will display the following:
Low-Level Cal - Step 5 of 13
13. The unit will display the following:
Connect 200mV @ 1kHz
14. Program the calibrator to output 200mV at a frequency of 1kHz, then press ENTER. The Model 2002 will then display the following:
Low-Level Cal - Step 6 of 13
15. When finished with this step, the unit will display the following:
Connect 5mV @ 100kHz
16. Set the calibrator to output 5mV at a frequency of 100kHz, then press ENTER. The Model 2002 will then display the following while calibrating:
Low-Level Cal - Step 7 of 13
17. Following step 7, the instrument will display the following message to prompt for the next calibration signal:
Connect 0.5mV @ 1kHz
18. Program the calibrator to output 0.5mV at 1kHz, then press ENTER. The unit will display the following in-progress message:
Low-Level Cal - Step 8 of 13
19. Next, the unit will prompt for the next calibration signal:
Connect 100 VDC

NOTE
The accuracy of the 100V source is especially critical. It may be necessary to adjust the calibrator output slightly to achieve exactly 100V.
20. Set the calibrator to output +100V DC, then press the ENTER key. The Model 2002 will advise you that the current step is in progress:
Low-Level Cal - Step 9 of 13
21. After this step has been completed, the unit will display the following:
Connect -20 VDC

NOTE
The accuracy of the -20V source is especially critical. It may be necessary to adjust the calibrator output slightly to achieve exactly -20V.
22. Set the calibrator for an output voltage of -20V DC, then press ENTER. The Model 2002 will display the following message:
Low-Level Cal - Step 10 of 13
23. The Model 2002 will then prompt for the next calibration signal:
Short Rear Inputs
24. Connect the Model 8610 to the rear INPUT jacks, making sure that the terminals are in the correct position. Select the rear inputs with the FRONT/REAR switch, and allow at least three minutes for thermal equilibrium. Press ENTER to continue. The Model 2002 will display the following:
Low-Level Cal - Step 11 of 13
25. After completing step 11, the unit will display the following:
Connect 20mA @ 1kHz
26. Connect the calibrator to the AMPS and INPUT LO jacks. (See Figure 2-3.) Press the FRONT/REAR switch to select the front inputs.
27. Set the calibrator output to 20mA AC at a frequency of 1kHz, then press the ENTER key. The Model 2002 will display the following while calibrating:
Low-Level Cal - Step 12 of 13
28. The unit will then prompt for the final calibration signal:
Connect 2 V at 1 Hz
29. Put the calibrator in standby, then disconnect it from the Model 2002 INPUT and AMPS jacks; connect the synthesizer to INPUT HI and LO, as shown in Figure 2-5. Set synthesizer modes as follows:
FCTN: sine
FREQ: 1Hz
AMPTD: 2Vrms
MODE: CONT
OFFSET: 0V

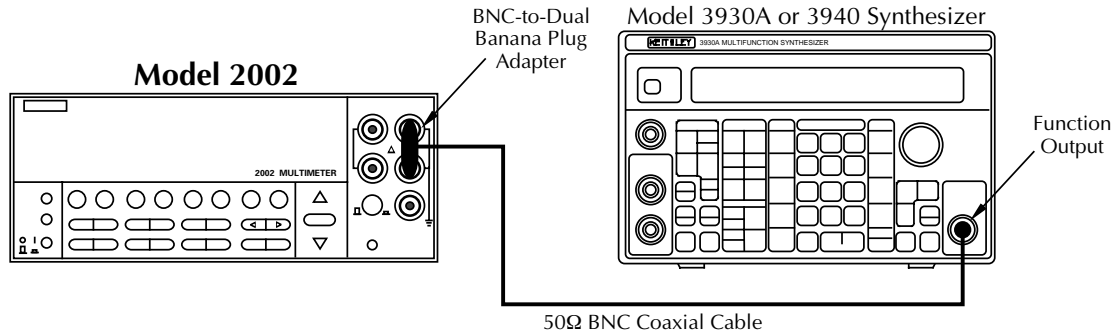

Figure 2-5
Synthesizer connections

30. Press the Model 2002 ENTER key. The instrument will display the following while calibrating:

Low-Level Cal - Step 13 of 13

31. After step 13 is completed, the instrument will display the following message to indicate that calibration has been completed:

CALIBRATION COMPLETE

Step 10: Enter calibration dates

1. Press ENTER. The instrument will prompt you to enter the calibration date:

CAL DATE: 01/01/94

2. Use the cursor and range keys to set the date as desired, then press ENTER. Press ENTER a second time to confirm your date selection.
3. The Model 2002 will then prompt you to enter the calibration due date:

NEXT CAL 01/01/95

4. Use the cursor keys to set the date as desired, then press ENTER. Press ENTER again to confirm your date.

Step 11: Save calibration constants

1. The Model 2002 will then display the following message:

CALIBRATION SUCCESS

2. If you wish to save the new calibration constants, press ENTER. If, on the other hand, you wish to restore previous calibration constants, cycle power.

3. Press EXIT as necessary to return to normal display.

NOTE

Calibration will be locked out automatically when the calibration procedure is completed.

2.10.4 IEEE-488 bus low-level calibration procedure

Follow the steps below to perform low-level calibration over the IEEE-488 bus. Table 2-6 summarizes calibration commands for the procedure.

Procedure

Step 1: Prepare the Model 2002 for calibration

1. Connect the Model 2002 to the IEEE-488 bus of the computer using a shielded IEEE-488 cable such as the Keithley Model 7007.
2. Make sure the primary address of the Model 2002 is the same as the address specified in the program you will be using to send commands.
3. Turn off the power if the instrument is presently turned on.
4. Press and hold the recessed CAL switch while turning on the power. (Holding in the CAL switch while turning on the power enables low-level calibration.)
5. Allow the Model 2002 to warm up for at least four hours before performing calibration.
6. Send the following command over the bus to the instrument to initiate calibration:

:CAL:PROT:INIT

Step 2: DC zero calibration

1. Connect the Model 8610 low-thermal short to the instrument INPUT and SENSE terminals, as shown in Figure 2-1. Wait at least three minutes before proceeding to allow for thermal equilibrium.

NOTE

Be sure to properly connect HI, LO, and SENSE terminals. Keep drafts away from low-thermal connections to avoid thermal drift, which could affect calibration accuracy.

2. Send the following command over the bus:
:CAL:PROT:DC:ZERO
3. Wait until the Model 2002 finishes this calibration step before proceeding. (You can use the *OPC or *OPC? commands to determine when calibration steps end, as discussed in paragraph 3.6 in Section 3.)

Step 3: DC volts calibration

1. Disconnect the low-thermal short, and connect the DC calibrator to the INPUT jacks, as shown in Figure 2-2.

NOTE

Although 4-wire connections are shown, the sense leads are connected and disconnected at various points in the procedure by turning calibrator external sense on or off as appropriate. If your calibrator does not have provisions for turning external sense on and off, disconnect the sense leads when external sensing is to be turned off, and connect the sense leads when external sensing is to be turned on.

2. Set the DC calibrator output to +2.00000V, and turn external sense off.
3. Send the following command to the Model 2002 over the IEEE-488 bus:

```
:CAL:PROT:DC:V2 2
```

(Be sure to use the exact calibration value as the command parameter if you are using a voltage other than 2V. The allowable range from is 0.95V to 2.05V).

NOTE

For best results, use the calibration values given in this procedure whenever possible.

4. Wait until the Model 2002 finishes this step before going on.

NOTE

You can check for errors after each calibration step by sending the :SYST:ERR? query to the instrument. See paragraph 2.7.2.

5. Set the DC calibrator output to +20.00000V.
6. Send the following command to the instrument:

```
:CAL:PROT:DC:V20 20
```

(Send the actual calibration value in the range of 9.5V to 20.5V if you are using a different voltage.)

7. Wait until the Model 2002 finishes this step before going on.

Step 4: Ohms calibration

1. Set the calibrator output to 1M Ω , and turn external sense on.
2. Send the following command to the Model 2002:

```
:CAL:PROT:DC:OHM1M <value>
```

Here, <value> is the actual calibrator resistance value. For example, if the calibrator resistance is 1.002M Ω , the command would appear as follows:

```
:CAL:PROT:DC:OHM1M 1.002E6
```

(The allowable range for this parameter is from 475E3 to 1.025E6.)

3. Wait until the Model 2002 finishes 1M Ω calibration before continuing.
4. Set the calibrator resistance to 100k Ω .

NOTE

External sense (4-wire ohms) should be used when calibrating all resistance ranges.

5. Repeat steps 2 and 3 for each of the remaining ohms calibration points shown in Table 2-9.

Table 2-9
Ohms calibration summary

Cal point	Nominal resistance	Allowable range	Command*
2M Ω	1M Ω	475k Ω to 1.025M Ω	:CAL:PROT:DC:OHM1M 1E6
200k Ω	100k Ω	95k Ω to 205k Ω	:CAL:PROT:DC:OHM200K 100E3
20k Ω	19k Ω	9.5k Ω to 20.5k Ω	:CAL:PROT:DC:OHM20K 19E3
2k Ω	1.9k Ω	0.95k Ω to 2.05k Ω	:CAL:PROT:DC:OHM2K 1.9E3
200 Ω	190 Ω	95 Ω to 205 Ω	:CAL:PROT:DC:OHM200 190
20 Ω	19 Ω	9.5 Ω to 20.5 Ω	:CAL:PROT:DC:OHM20 19

* Nominal resistance values shown. Use exact calibrator resistance value for command parameter.

Step 5: Amps calibration

1. Connect the calibrator to the AMPS and INPUT LO jacks, as shown in Figure 2-3.
2. Set the calibrator output to 200.000 μ A, and place the unit in operate.
3. Send the following command to the Model 2002:
:CAL:PROT:DC:A200U 200E-6

If you are using a different calibration value, be sure to substitute that value for the parameter shown above. (The allowable range is from 95 μ A to 205 μ A.)

Wait for the instrument to complete this step before continuing.

4. Repeat steps 2 and 3 for the following remaining amps shown in Table 2-10.

Step 6. Open-circuit calibration

1. Disconnect all test leads from the Model 2002 INPUT and AMPS jacks.
2. Send the following command to the instrument:
:CAL:PROT:DC:OPEN
3. Wait until open-circuit calibration is complete before going on to the next step.

Step 7: Perform AC user calibration

To perform user AC calibration, send the following command:

:CAL:UNPR:ACC

Note that AC calibration will take about six minutes to complete.

Table 2-10
Amps calibration summary

Cal point	Calibrator current	Allowable range	Calibration command
200 μ A	200.000 μ A	0.95 μ A to 205 μ A	:CAL:PROT:DC:A200U 200E-6
2mA	2.00000mA	0.95mA to 2.05mA	:CAL:PROT:DC:A2M 2E-3
20mA	20.0000mA	9.5mA to 20.5mA	:CAL:PROT:DC:A20M 20E-3
200mA	200.000mA	95mA to 205mA	:CAL:PROT:DC:A200M 200E-3
2A	1.00000A	0.95A to 2.05A	:CAL:PROT:DC:A2 1

*Step 8: Perform low-level calibration steps***NOTE**

The following steps perform the low-level part of the calibration procedure. Use only the indicated calibration values for these steps. Be sure the instrument completes each step before sending the next calibration command.

1. Connect the Model 2002 to the calibrator using 2-wire connections, as shown in Figure 2-4.
2. Program the calibrator to output 20V AC at a frequency of 1kHz, then send the following command to the Model 2002:
:CAL:PROT:LLEV:STEP 1
3. Program the calibrator to output 20V AC at a frequency of 30kHz, and send the following command to the Model 2002:
:CAL:PROT:LLEV:STEP 2
4. Set the calibrator output to 200V AC at 1kHz, then send the following command:
:CAL:PROT:LLEV:STEP 3
5. Set the calibrator output to 200V AC at a frequency of 30kHz, then send the following command:
:CAL:PROT:LLEV:STEP 4
6. Program the calibrator to output 1.5V AC at a frequency of 1kHz. Send the following command to the Model 2002:
:CAL:PROT:LLEV:STEP 5
7. Program the calibrator to output 200mV AC at a frequency of 1kHz, and send the following command to the Model 2002:
:CAL:PROT:LLEV:STEP 6
8. Set the calibrator output to 5mV AC at a frequency of 100kHz. Send the following command to the Model 2002:
:CAL:PROT:LLEV:STEP 7
9. Program the calibrator to output 0.5mV AC at a frequency of 1kHz. Send the following command to the Model 2002:
:CAL:PROT:LLEV:STEP 8
10. Set the calibrator output to +100V DC. Send the following command to the Model 2002:
:CAL:PROT:LLEV:STEP 9

NOTE

The accuracy of the 100V calibration source is especially critical. It may be necessary to adjust the calibrator output slightly to achieve exactly 100V.

11. Program the calibrator to output -20V DC, and send the following command to the Model 2002:

```
:CAL:PROT:LLEV:STEP 10
```

NOTE

The accuracy of the -20V source is especially critical. It may be necessary to adjust the calibrator output slightly to achieve exactly -20V.

12. Connect the Model 8610 calibration short to the rear panel INPUT jacks, making sure to connect the terminals properly. Select the rear inputs with the FRONT/REAR switch, and allow at least three minutes for thermal equilibrium. Send the following command:
:CAL:PROT:LLEV:STEP 11
13. Connect the calibrator to the AMPS and INPUT LO terminals, as shown in Figure 2-3. Select the front inputs with the FRONT/REAR switch.
14. Program the calibrator to output 20mA AC at a frequency of 1kHz. Send the following command to the Model 2002:
:CAL:PROT:LLEV:STEP 12
15. Connect the multifunction synthesizer to the Model 2002, as shown in Figure 2-5.
16. Set the synthesizer operating modes as follows:
FCTN: sine
FREQ: 1Hz
AMPTD: 2V_{rms}
MODE: CONT
OFFSET: 0V
17. Send the following command to the Model 2002:
:CAL:PROT:LLEV:STEP 13

Step 9: Enter calibration dates

Use following commands to set the calibration date and calibration due date:

```
:CAL:PROT:DATE <yr>, <mon>, <day>
```

```
:CAL:PROT:NDUE <yr>, <mon>, <day>
```

Note that the year, month, and date must be separated by commas.

Step 10: Save calibration constants

Calibration is now complete, so you can store the calibration constants in EEROM by sending the following command:

```
:CAL:PROT:SAVE
```

Step 11: Lock out calibration

To lock out further calibration, send the following command after completing the calibration procedure:

```
:CAL:PROT:LOCK
```

2.11 Single-point calibration

Normally, the complete comprehensive (or low-level, if necessary) calibration procedure should be performed to ensure that the entire instrument is properly calibrated. In some instances, however, it may be desirable to calibrate only certain ranges and functions. For those cases, a single-point calibration feature is included in the Model 2002.

The following paragraphs give an overview of performing single-point calibration both from the front panel and over the IEEE-488 bus. For details on specific procedures, test equipment connections, and IEEE-488 bus commands, refer to paragraphs 2.6 through 2.10 of this section.

Remember that calibration must be unlocked (except for AC only user calibration). To unlock point calibration, press in on the CAL switch.

2.11.1 Front panel single-point calibration

Front panel single-point calibration can be performed by using the POINT-CALS selection in the CALIBRATION menu. You will then be prompted as to which function to calibrate: DCV, DCI, or OHMS. If you select DCI or OHMS, you will also be able to select the range to calibrate, and will then be prompted to apply the appropriate calibration signal. See paragraph 2.8 for details on comprehensive calibration steps.

If you enable low-level calibration by holding in the CAL switch while turning on the power, the LL-CAL (low-level calibration) selection will also appear in the POINT-CALS menu. You can then calibrate a specific low-level point (see paragraph 2.10 for details).

Example

Assume that you wish to calibrate the 2k Ω range. Follow the steps below to do so.

1. Turn on the Model 2002, and allow the instrument to warm up for at least four hours before performing calibration.
2. Press in on the front panel CAL switch to unlock calibration.
3. Press the MENU key. The instrument will display the following menu:

```
MAIN MENU
SAVESETUP GPIB CALIBRATION
```

4. Select CALIBRATION, then press ENTER. The following menu will be displayed:

```
PERFORM CALIBRATION
COMPREHENSIVE POINT-CALS
```

5. Select POINT-CALS, then press ENTER. The Model 2002 will prompt you to select the function:

```
POINT CALIBRATION
AC-CAL DCV OHMS DCI
```

6. Select OHMS, then press ENTER. The unit will prompt you to choose the range:

```
CHOOSE OHMS RANGE
20 $\Omega$  200 $\Omega$  2k $\Omega$  20k $\Omega$  200k $\Omega$ 
```

7. Select 2k Ω , then press ENTER. The unit will prompt you to apply the appropriate calibration signal:

```
CONNECT 2K $\Omega$  4W
```

8. Connect the 2k Ω (or closest available value) to the INPUT and SENSE jacks using the 4-wire connections shown in Figure 2-1. Press ENTER.
9. Use the range and cursor keys to set the displayed resistance value to the exact calibration resistance, then press ENTER.
10. Repeat the above steps for other calibration points, if desired.
11. If desired, select CALIBRATION-DATES in the calibration menu, then set the calibration date and due date accordingly.
12. Press EXIT as necessary to return to normal display. Valid calibration constants will be saved, and calibration will be locked out.

2.11.2 IEEE-488 bus single-point calibration

To perform IEEE-488 bus single-point calibration, simply connect the appropriate signal, then send the corresponding calibration command. (See Table 2-4 for a summary of com-

prehensive commands, or Table 2-8 for low-level commands.) Remember that you must unlock calibration first.

Before sending any calibration commands, you must send the ":CAL:PROT:INIT" command to initialize calibration. After calibrating the desired point(s), you must then save the new calibration constants by sending the ":CAL:PROT:SAVE" command over the bus. You can then lock out calibration by sending ":CAL:PROT:LOCK".

Example

As an example, assume that you intend to calibrate the 2k Ω range. The basic steps are summarized below:

1. Turn on the Model 2002 power, and allow the instrument to warm up for at least four hours before performing calibration.
2. Press the front panel CAL switch to unlock calibration.
3. Send the following command over the bus to initiate calibration:

:CAL:PROT:INIT
4. Connect the 2k Ω (or closest available value) calibration source to the front panel INPUT and SENSE jacks using the 4-wire connections shown in Figure 2-1.

5. Send the following calibration command over the bus:

```
:CAL:PROT:DC:OHM2K 2E3
```

Be sure to substitute the exact calibration resistance value for the 2E3 parameter in the above command. For example, if the resistance value is 1.90034k Ω , the command would appear as follows:

```
:CAL:PROT:DC:OHM2K 1.90034E3
```

6. Repeat steps 4 and 5 as desired for other calibration points.
7. If desired, send the following commands to program the calibration date and calibration due date:

```
:CAL:PROT:DATE <yr>,<mon>,<day>  
:CAL:PROT:NDUE <yr>,<mon>,<day>
```

8. Send the following command to save calibration constants:

```
:CAL:PROT:SAVE
```

9. Finally, send the following command to lock out calibration:

```
:CAL:PROT:LOCK
```

3

Calibration Command Reference

3.1 Introduction

This section contains detailed information on the various Model 2002 IEEE-488 bus calibration commands. Section 2 of this manual covers detailed calibration procedures, and Appendix B lists calibration programs. For information on additional commands to control other instrument functions, refer to the Model 2002 User's Manual.

Information in this section includes:

- 3.2 **Command summary:** Summarizes all commands necessary to perform comprehensive, AC, and low-level calibration.
- 3.3 **CALibration:PROTected Subsystem:** Gives detailed explanations of the various commands used for both comprehensive and low-level calibration.

- 3.4 **CALibration:UNPRotected Subsystem:** Discusses the :ACC command, which is used to perform AC user calibration over the bus.

- 3.5 **Bus error reporting:** Summarizes bus calibration errors, and discusses how to obtain error information.

- 3.6 **Detecting calibration step completion:** Covers how to determine when each calibration step is completed by using the *OPC and *OPC? commands.

3.2 Commands

3.2.1 Command summary

Table 3-1 summarizes Model 2002 calibration commands along with the paragraph number where a detailed description of each command is located.

Table 3-1
IEEE-488 bus calibration command summary

Command	Description	Paragraph
:CALibration	Calibration root command.	
:PROTEcted	All commands in this subsystem are protected by the CAL switch (except queries).	3.3
:INITiate	Initiate calibration.	3.3.1
:LOCK	Lock out calibration (opposite of enabling cal with CAL switch).	3.3.2
:SWITCh?	Request comprehensive CAL switch state. (0 = locked; 1 = unlocked)	3.3.3
:SAVE	Save cal constants to EEROM.	3.3.4
:DATA?	Download cal constants from 2002.	3.3.5
:DATE <yr>, <mon>, <day>	Send cal date to 2002.	3.3.6
:DATE?	Request cal date from 2002.	
:NDUE <yr>, <mon>, <day>	Send next due cal date to 2002.	3.3.7
:NDUE?	Request next due cal date from 2002.	
:DC	Comprehensive calibration subsystem.	3.3.8
:ZERO	Low-thermal short calibration step.	
:V2 <Nrf>	+2V DC calibration step.	
:V20 <Nrf>	+20V DC calibration step.	
:OHM1M <Nrf>	1MΩ calibration step.	
:OHM200K <Nrf>	200kΩ calibration step.	
:OHM20K <Nrf>	20kΩ calibration step.	
:OHM2K <Nrf>	2kΩ calibration step.	
:OHM200 <Nrf>	200Ω calibration step.	
:OHM20 <Nrf>	20Ω calibration step.	
:A200U <Nrf>	200μA DC calibration step.	
:A2M <Nrf>	2mA DC calibration step.	
:A20M <Nrf>	20mA DC calibration step.	
:A200M <Nrf>	200mA DC calibration step.	
:A2 <Nrf>	2A DC calibration step.	
:OPEN	Open circuit calibration step.	
:LLEVeL	Low-level calibration subsystem.	3.3.9
:SWITCh?	Request low-level CAL switch state. (0 = locked; 1 = unlocked)	
:STEP <Step #>		
1	20V AC at 1kHz step.	
2	20V AC at 30kHz step.	
3	200V AC at 1kHz step.	
4	200V AC at 30kHz	
5	1.5V AC at 1kHz step.	
6	200mV AC at 1kHz step.	
7	5mV AC at 100kHz step.	
8	0.5mV AC at 1kHz step.	
9	+100V DC step.	
10	-20V DC step.	
11	Rear inputs short-circuit step.	
12	20mA AC at 1kHz step.	
13	2V AC at 1Hz step.	
:UNPRotected	Command in this subsystem not protected by CAL switch.	3.4
:ACCompensation	Perform user AC calibration (disconnect all cables)	

NOTE: Upper case letters indicated short form of each command. For example, instead of sending ":CALibration:PROTEcted:INITiate", you can send ":CAL:PROT:INIT".

3.3 :CALibration:PROTECTED Subsystem

The calibration protected subsystem commands perform all Model 2002 calibration except for AC-only calibration. All commands in this subsystem are protected by the calibration lock (CAL switch). The following paragraphs discuss these commands in detail.

3.3.1 :INIT (:CALibration:PROTECTED:INITiate)

Purpose	To initiate comprehensive and low-level calibration procedures.	
Format	:cal:prot:init	
Parameter	None	
Description	The :INIT command enables Model 2002 calibration when performing these procedures over the bus. In general, this command must be sent to the unit before sending any other comprehensive or low-level calibration command.	
Programming Note	The :INIT command should be sent only once before performing either complete or single-point calibration. Do not send :INIT before each calibration step.	
Example	:CAL:PROT:INIT	Initiate calibration

3.3.2 :LOCK (:CALibration:PROTECTED:LOCK)

Purpose	To lock out comprehensive or low-level calibration.	
Format	:cal:prot:lock	
Parameter	None	
Description	The :LOCK command allows you to lock out both comprehensive and low-level calibration after completing those procedures. Thus, :LOCK performs the opposite of pressing in on the front panel CAL switch.	
Programming Note	To unlock comprehensive calibration, press in on the CAL switch with the power turned on. To unlock low-level calibration, hold in the CAL switch while turning on the power.	
Example	:CAL:PROT:LOCK	Lock out calibration

3.3.3 :SWITCh? (:CALibration:PROTected:SWITCh?)

Purpose To read comprehensive calibration lock status.

Format :cal:prot:swit?

Response
 0 Comprehensive calibration locked
 1 Comprehensive calibration unlocked.

Description The :SWITCh? query requests status from the Model 2002 on calibration locked/unlocked state. Calibration must be unlocked by pressing in on the CAL switch while power is turned on before calibration can be performed.

Programming Note The :CAL:PROT:SWIT? query does not check the status of the low-level calibration lock, which can be checked by using the :CAL:PROT:LLEV:SWIT? query. (See paragraph 3.3.9.)

Example :CAL:PROT:SWIT? Request CAL switch status.

3.3.4 :SAVE (:CALibration:PROTected:SAVE)

Purpose To save calibration constants in EEROM after the calibration procedure.

Format :cal:prot:save

Parameter None

Description The :SAVE command stores internally calculated calibration constants derived during both comprehensive and low-level calibration in EEROM. EEROM is non-volatile memory, and calibration constants will be retained indefinitely once saved. Generally, :SAVE is sent after all other calibration steps (except for :LOCK).

Programming Note Calibration will be only temporary unless the :SAVE command is sent to permanently store calibration constants.

Example :CAL:PROT:SAVE Save calibration constants

3.3.5 :DATA? (:CALibration:PROTected:DATA?)

Purpose To download calibration constants from the Model 2002

Format :cal:prot:data?

Response <Cal_1>,<Cal_2>,...<Cal_n>

Description :DATA? allows you to request the current calibration constants stored in EEROM from the instrument. This command can be used to compare present constants with those from a previous calibration procedure to verify that calibration was performed properly. The returned values are floating-point numbers using ASCII representation delimited by commas (,).

Programming Note See Appendix C for a summary of calibration constant values returned by the :DATA? query.

Example :CAL:PROT:DATA? Request calibration constants.

3.3.6 :DATE (:CALibration:PROTected:DATE)

Purpose	To send the calibration date to the instrument.	
Format	:cal:prot:date <yr>, <mon>, <day>	
Parameters	<yr> = year (yyyy, 1993 to 2092) <mon> = month (mm, 1 to 12) <day> = day of month (dd, 1 to 31)	
Query Format	:cal:prot:date?	
Response	<yr>, <mon>, <day>	
Description	The :DATE command allows you to store the calibration date in instrument memory for future reference. You can read back the date from the instrument over the bus by using the :DATE? query, or by using the CALIBRATION selection in the front panel menu.	
Programming Note	The year, month, and day parameters must be delimited by commas.	
Examples	:CAL:PROT:DATE 1994,12,16	Send cal date (12/16/94).
	:CAL:PROT:DATE?	Request date.

3.3.7 :NDUE (:CALibration:PROTected:NDUE)

Purpose	To send the next calibration due date to the instrument.	
Format	:cal:prot:ndue <yr>, <mon>, <day>	
Parameters	<yr> = year (yyyy, 1993 to 2092) <mon> = month (mm, 1 to 12) <day> = day of month (dd, 1 to 31)	
Query Format	:cal:prot:ndue?	
Response	<yr>, <mon>, <day>	
Description	The :NDUE command allows you to store the date when calibration is next due in instrument memory. You can read back the next due date from the instrument over the bus by using the :NDUE? query, or by using the CALIBRATION-DATES selection in the front panel menu.	
Programming Note	The next due date parameters must be delimited by commas.	
Examples	:CAL:PROT:NDUE 1995,12,16	Send due date (12/16/95).
	:CAL:PROT:NDUE?	Request due date.

3.3.8 :DC (:CALibration:PROtected:DC)

The :DC commands perform comprehensive (user) calibration. Table 3-2 summarizes these comprehensive calibration commands along with parameter limits.

Table 3-2
Comprehensive calibration commands

Command	Description	Parameter limits
:CALibration :PROtected :DC	User calibration subsystem.	
:ZERO	Short-circuit calibration	
:V2 <NRf>	+2V DC calibration step	0.95 to 2.05
:V20 <NRf>	+20V DC calibration step.	9.5 to 20.5
:OHM1M <NRf>	1MΩ calibration step.	475E3 to 1.025E6
:OHM200K <NRf>	200kΩ calibration step.	95E3 to 205E3
:OHM20K <NRf>	20kΩ calibration step.	9.5E3 to 20.5E3
:OHM2K <NRf>	2kΩ calibration step.	950 to 2.05E3
:OHM200 <NRf>	200Ω calibration step.	95 to 205
:OHM20 <NRf>	20Ω calibration step.	9.5 to 20.5
:A200U <NRf>	200μA DC calibration step.	95E-6 to 205E-6
:A2M <NRf>	2mA DC calibration step.	0.95E-3 to 2.05E-3
:A20M <NRf>	20mA DC calibration step.	9.5E-3 to 20.5E-3
:A200M <NRf>	200mA DC calibration step.	95E-3 to 205E-3
:A2 <NRf>	2A DC calibration step.	0.95 to 2.05
:OPEN	Open-circuit calibration step.	

:ZERO (:CALibration:PROtected:DC:ZERO)

Purpose	To perform short-circuit comprehensive calibration.	
Format	:cal:prot:dc:zero	
Parameter	none	
Description	:ZERO performs the short-circuit calibration step in the comprehensive calibration procedure. A low-thermal short (Model 8610) must be connected to the input jacks before sending this command.	
Example	:CAL:PROT:DC:ZERO	Perform zero calibration.

	:V2 (:CALibration:PROTected:DC:V2)	
Purpose	To program the +2V comprehensive calibration step.	
Format	:cal:prot:dc:v2 <Cal_voltage>	
Parameter	<Cal_voltage> = 0.95 to 2.05 [V]	
Description	:V2 programs the +2V DC comprehensive calibration step. The allowable range of the calibration voltage parameter is from 0.95 to 2.05V, but 2V is recommended for best results.	
Example	:CAL:PROT:DC:V2 2	Program 2V step.
	:V20 (:CALibration:PROTected:DC:V20)	
Purpose	To program the +20V DC comprehensive calibration step.	
Format	:cal:prot:dc:v20 <Cal_voltage>	
Parameter	<Cal_voltage> = 9.5 to 20.5 [V]	
Description	:V2 programs the +20V DC comprehensive calibration step. The allowable range of the calibration voltage parameter is from 9.5 to 20.5V, but 20V is recommended for best results.	
Example	:CAL:PROT:DC:V20 20	Program 20V step.
	:OHM1M (CALibration:PROTected:DC:OHM1M)	
Purpose	To program the 1M Ω comprehensive calibration step.	
Format	:cal:prot:dc:ohm1m <Cal_resistance>	
Parameter	<Cal_resistance> = 475E3 to 1.025E6 [Ω]	
Description	:OHM1M programs the 1M Ω comprehensive calibration step. The allowable range of the calibration resistance parameter is from 475k Ω to 1.025M Ω . Use the 1M Ω value whenever possible, or the closest possible value.	
Example	:CAL:PROT:DC:OHM1M 1E6	Program 1M Ω cal step.

	:OHM200K (CALibration:PROTected:DC:OHM200K)
Purpose	To program the 200k Ω comprehensive calibration step.
Format	:cal:prot:dc:ohm200k <Cal_resistance>
Parameter	<Cal_resistance> = 95E3 to 205E3 [Ω]
Description	:OHM200K programs the 200k Ω comprehensive calibration step. The allowable range of the calibration resistance parameter is from 95k Ω to 205k Ω . Use a 100k Ω value whenever possible, or the closest possible value.
Example	:CAL:PROT:DC:OHM200K 100E3 Program 200k Ω step.
	:OHM20K (CALibration:PROTected:DC:OHM20K)
Purpose	To program the 20k Ω comprehensive calibration step.
Format	:cal:prot:dc:ohm20k <Cal_resistance>
Parameter	<Cal_resistance> = 9.5E3 to 20.5E3 [Ω]
Description	:OHM20K programs the 20k Ω comprehensive calibration step. The allowable range of the calibration resistance parameter is from 9.5k Ω to 20.5k Ω . Use the 20k Ω value whenever possible, or the closest possible value (for example, 19k Ω , which is the closet value available on many calibrators).
Example	:CAL:PROT:DC:OHM20K 19E3 Program 20k Ω step.
	:OHM2K (CALibration:PROTected:DC:OHM2K)
Purpose	To program the 2k Ω comprehensive calibration step.
Format	:cal:prot:dc:ohm2k <Cal_resistance>
Parameter	<Cal_resistance> = 950 to 2.05E3 [Ω]
Description	:OHM2K programs the 2k Ω comprehensive calibration step. The allowable range of the calibration resistance parameter is from 0.95k Ω to 2.05k Ω . Use the 2k Ω value whenever possible, or the closest possible value (for example, 1.9k Ω , which is the closet value available on many calibrators).
Example	:CAL:PROT:DC:OHM2K 1.9E3 Program 2k Ω step.

	:OHM200 (CALibration:PROTected:DC:OHM200)
Purpose	To program the 200Ω comprehensive calibration step.
Format	:cal:prot:dc:ohm200 <Cal_resistance>
Parameter	<Cal_resistance> = 95 to 205 [Ω]
Description	:OHM200 programs the 200Ω comprehensive calibration step. The allowable range of the calibration resistance parameter is from 95Ω to 205Ω. Use the 200Ω value whenever possible, or the closest possible value (for example, 190Ω, which is the closest value available on many calibrators).
Example	:CAL:PROT:DC:OHM200 190 Program 200Ω step.
	:OHM20 (CALibration:PROTected:DC:OHM20)
Purpose	To program the 20Ω comprehensive calibration step.
Format	:cal:prot:dc:ohm20 <Cal_resistance>
Parameter	<Cal_resistance> = 9.5 to 20.5 [Ω]
Description	:OHM20 programs the 20Ω comprehensive calibration step. The allowable range of the calibration resistance parameter is from 9.5Ω to 20.5kΩ. Use the 20Ω value whenever possible, or the closest possible value (for example, 19Ω, which is the closest value available on many calibrators).
Example	:CAL:PROT:DC:OHM20 19 Program 20Ω step.
	:A200U (CALibration:PROTected:DC:A200U)
Purpose	To program the 200μA comprehensive calibration step.
Format	:cal:prot:dc:a200u <Cal_current>
Parameter	<Cal_current> = 95E-6 to 205E-6 [A]
Description	:A200U programs the 200μA comprehensive calibration step. The allowable range of the calibration current parameter is from 95μA to 205μA. Use the 200μA value whenever possible for best results.
Example	:CAL:PROT:DC:A200U 200E-6 Program 200μA step.

:A2M (CALibration:PROTected:DC:A2M)

Purpose	To program the 2mA comprehensive calibration step.	
Format	:cal:prot:dc:a2m <Cal_current>	
Parameter	<Cal_current> = 0.95E-3 to 2.05E-3 [A]	
Description	:A2M programs the 2mA comprehensive calibration step. The allowable range of the calibration current parameter is from 0.95mA to 2.05µA. Use the 2mA value whenever possible for best results.	
Example	:CAL:PROT:DC:A2M 2E-3	Program 2mA step.

:A20M (CALibration:PROTected:DC:A20M)

Purpose	To program the 20mA comprehensive calibration step.	
Format	:cal:prot:dc:a20m <Cal_current>	
Parameter	<Cal_current> = 9.5E-3 to 20.5E-3 [A]	
Description	:A200U programs the 20mA comprehensive calibration step. The allowable range of the calibration current parameter is from 9.5mA to 20.5mA. Use the 20mA value whenever possible for best results.	
Example	:CAL:PROT:DC:A20M 20E-3	Program 20mA step.

:A200M (CALibration:PROTected:DC:A200M)

Purpose	To program the 200mA comprehensive calibration step.	
Format	:cal:prot:dc:a200m <Cal_current>	
Parameter	<Cal_current> = 95E-3 to 205E-3 [A]	
Description	:A200M programs the 200mA comprehensive calibration step. The allowable range of the calibration current parameter is from 95mA to 205mA. Use the 200mA value whenever possible for best results.	
Example	:CAL:PROT:DC:A200M 200E-3	Program 200mA step.

	:A2 (CALibration:PROTected:DC:A2)	
Purpose	To program the 2A comprehensive calibration step.	
Format	:cal:prot:dc:a2 <Cal_current>	
Parameter	<Cal_current> = 0.95 to 2.05 [A]	
Description	A2 programs the 2A comprehensive calibration step. The allowable range of the calibration current parameter is from 0.95A to 2.05A. Use the 1A value whenever possible for best results.	
Example	:CAL:PROT:DC:A2 1	Program 2A step.

3.3.9 :LLEVel (CALibration:PROTected:LLEVel)

Low-level calibration commands are summarized in Table 3-3.

Table 3-3
Low-level calibration commands

Command	Description
:CALibration :PROTected :LLEVel :SWITCh?	Low-level calibration subsystem. Request low-level CAL switch state. (0 = locked; 1 = unlocked)
:STEP <Step #>	
1	20V AC at 1kHz step.
2	20V AC at 30kHz step.
3	200V AC at 1kHz step.
4	200V AC at 30kHz step.
5	1.5V AC at 1kHz step.
6	0.2V AC at 1kHz step.
7	5mV AC at 100kHz step.
8	0.5mV AC at 1kHz step.
9	+100V DC step.
10	-20V DC step.
11	Rear inputs short-circuit step.
12	20mA AC at 1kHz step.
13	2V AC at 1Hz step.

:SWITCh? (CALibration:PROTected:LLEVel:SWITCh?)

Purpose To request the state of the low-level calibration lock.

Format :cal:prot:llev:swit?

Response
 0 Low-level calibration locked
 1 Low-level calibration unlocked

Description :SWITCh? query requests the status of the low-level calibration lock from the instrument. This :SWITCh? query should not be confused with the :SWITCh? query that requests the status of the comprehensive calibration lock (see paragraph 3.3.2.)

Programming Note To unlock low-level calibration, hold in the CAL switch while turning on instrument power.

:CAL:PROT:LLEV:SWIT? Request low-level CAL switch status.

:STEP (CALibration:PROTected:LLEVel:STEP)

Purpose To program individual low-level calibration steps.

Format :cal:prot:llev:step <n>

Parameters

- 1 20V AC @ 1kHz
- 2 20V AC @ 30kHz
- 3 200V AC @ 1kHz
- 4 200V AC @ 30kHz
- 5 1.5V AC @ 1kHz
- 6 200mV AC @ 1kHz
- 7 5mV AC @ 100kHz
- 8 0.5mV AC @ 1kHz
- 9 +100V DC
- 10 -20V DC
- 11 Rear inputs short-circuit.
- 12 20mA AC @ 1kHz
- 13 2V AC @ 1HZ

Description The :STEP command programs the 13 individual low-level calibration steps; <n> represents the calibration step number. The appropriate signal must be connected to the instrument when programming each step, as summarized in the parameters listed above (see Section 2 for details).

Example :CAL:PROT:LLEV:STEP 7 Program low-level step 7.

3.4 :CALibration:UNPRotected Subsystem

3.4.1 :ACCompensation (:CALibration:UNPRotected:ACCompensation)

Purpose	To perform user AC calibration	
Format	:cal:unpr:acc	
Parameter	None	
Description	The :ACC command performs user AC calibration, which requires no calibration equipment. All test leads must be disconnected from the input jacks when performing user AC calibration.	
Programming Note	Calibration constants generated by using the :ACC command are not stored in EEROM. Thus, AC calibration constants are in effect only until the instrument is turned off. In order to save AC calibration constants, perform the comprehensive calibration procedure, then use the :SAVE command. Note that AC calibration takes about six minutes to complete.	
Example	:CAL:UNPR:ACC	Perform AC user cal.

3.5 Bus error reporting

3.5.1 Calibration error summary

Refer to Appendix C for a summary of calibration errors and additional information on specific errors.

3.5.2 Detecting Calibration Errors

If an error occurs during any calibration step, the Model 2002 will generate an error message. Several methods to detect calibration errors are discussed in the following paragraphs. The calibration programs listed in Appendix B may be used as examples for some of these methods.

Error queue

As with other Model 2002 errors, any calibration errors will be reported in the bus error queue. You can read this queue by using the :SYST:ERR? query. The Model 2002 will respond with the appropriate error message, as summarized in Appendix C.

Status Byte EAV (Error Available) Bit

Whenever an error is available in the error queue, the EAV (Error Available) bit (bit 2) of the status byte will be set. Use the *STB? query or serial polling to obtain the status byte, then test bit 2 to see if it is set. If the EAV bit is set, an error has occurred, and you can use the :SYST:ERR? query to read the error and at the same time clear the EAV bit in the status byte.

Generating an SRQ on error

To program the instrument to generate an SRQ when an error occurs, send the following command: *SRE 4. This command will enable SRQ when the EAV bit is set. You can then read the status byte and error queue as outlined above to check for errors and to determine the exact nature of the error.

3.6 Detecting calibration step completion

When sending calibration commands over the IEEE-488 bus, you must wait until the instrument completes the current operation before sending a command. You can use either `*OPC?` or `*OPC` to help determine when each calibration step is completed. (The example programs in Appendix B use the `*OPC` command to detect when each calibration step is completed.)

3.6.1 Using the `*OPC?` Query

With the `*OPC?` (operation complete) query, the instrument will place an ASCII 1 in the output queue when it has completed each step. To determine when the OPC response is ready, do the following:

1. Repeatedly test the MAV (Message Available) bit (bit 4) in the status byte and wait until it is set. (You can request the status byte by using the `*STB?` query or serial polling.)
2. When MAV is set, a message is available in the output queue, and you can read the output queue and test for an ASCII 1.
3. After reading the output queue, repeatedly test MAV again until it clears. At this point, the calibration step is completed.

3.6.2 Using the `*OPC` command

The `*OPC` (operation complete) command can also be used to detect the completion of each calibration step. In order to use `*OPC` to detect the end of each calibration step, you must do the following:

1. Enable operation complete by sending `*ESE 1`. The command sets the OPC (operation complete bit) in the standard event enable register, allowing operation complete status from the standard event status register to set the ESB (event summary bit) in the status byte when operation complete is detected.
2. Send the `*OPC` command immediately following each calibration command. For example:

```
:CAL:PROT:DC:ZERO;*OPC
```

Note that you must include the semicolon (;) to separate the two commands, and that the `*OPC` command must appear on the same line as the calibration command.

3. After sending a calibration command, repeatedly test the ESB (Event Summary) bit (bit 5) in the status byte until it is set. (Use either the `*STB?` query or serial polling to request the status byte.)
4. Once operation complete has been detected, clear OPC status using one of two methods: (1) Use the `*ESR?` query, then read the response to clear the standard event status register, or (2) Send the `*CLS` command to clear the status registers. Note that sending `*CLS` will also clear the error queue and operation complete status.

3.6.3 Generating an SRQ on calibration complete

An SRQ (service request) can be used to detect operation complete instead of repeatedly polling the Model 2002. To use this method, send both `*ESE 1` and `*SRE 32` to the instrument, then include the `*OPC` command at the end of each calibration command line, as covered in paragraph 3.6.2 above. Refer to your controller's documentation for information on detecting and servicing SRQs. The example calibration programs in Appendix B demonstrate how to use SRQ to detect the end of each calibration step.

A Specifications

Specifications

The following pages contain the complete specifications for the 2002. Every effort has been made to make these specifications complete by characterizing its performance under the variety of conditions often encountered in production, engineering, and research.

The 2002 provides Transfer, 24-hour, 90-day, 1-year, and 2-year specifications, with full specifications for the 90-day, 1-year, and 2-year intervals. This allows the operator to utilize 90-day, 1-year, or 2-year recommended calibration intervals, depending upon the level of accuracy desired. As a general rule, the 2002's 2-year performance exceeds a 6½-digit DMM's 90-day, 180-day, or 1-year specifications.

Absolute Accuracy

All DC specifications are given as relative accuracies. To obtain absolute accuracies, the absolute uncertainties of the calibration sources must be added to the relative accuracies. The absolute uncertainties for the calibration sources used during Keithley's factory calibration are included in the specifications. The uncertainties of the operator's sources may be different.

All AC specifications are given as absolute accuracies.

Typical Accuracies

Accuracy can be specified as typical or warranted. All specifications shown are warranted unless specifically noted. Almost 99% of the 2002's specifications are warranted specifications. In some cases it is not possible to obtain sources to maintain traceability on the performance of every unit in production on some measurement (e.g., high-voltage, high frequency signal sources with sufficient accuracy do not exist). These values are listed as typical.

2002 Specified Calibration Intervals

Measurement Function	24 Hour ¹	90 Day ²	1 Year ²	2 Year ²
DC Volts	•	•	•	•
DC Volts Peak Spikes		•	•	•
AC Volts rms		• ³	• ³	• ³
AC Volts Peak		•	•	•
AC Volts Average		• ³	• ³	• ³
AC Volts Crest Factor		•	•	•
Ohms	•	•	•	•
DC Current	•	•	•	•
DC In-Circuit Current		•	•	•
AC Current		•	•	•
Frequency		•	•	•
Temperature (Thermocouple)		•	•	•
Temperature (RTD)	•	•	•	•

¹ For $T_{CAL} \pm 1^{\circ}C$.

² For $T_{CAL} \pm 5^{\circ}C$.

³ For $\pm 2^{\circ}C$ of last AC self-cal.

DC Volts

DCV Input Characteristics and Accuracy

Enhanced Accuracy¹ – 10PLC, DFILT 10

Range	Full Scale	Resolution	Input Resistance	Transfer ¹²	Relative Accuracy ±(ppm of reading + ppm of range)				Temperature Coefficient ±(ppm of reading + ppm of range)/°C Outside T _{Cal} ±5°C
					24 Hours ²	90 Days ³	1 Year ³	2 Years ³	
200 mV ⁴	±210.000000	1 nV	>100 GΩ	0.4 + 1.5	3.5 + 3	15 + 8	19 + 9	23 + 10	2 + 1.8
2 V ⁴	±2.10000000	10 nV	>100 GΩ	0.2 + 0.15	1.2 + 0.3	6 + 0.8	10 + 0.9	14 + 1	0.2 + 0.18
20 V	±21.00000000	100 nV	>100 GΩ	0.1 + 0.05	1.2 + 0.1	6 + 0.15	10 + 0.15	14 + 0.15	0.3 + 0.02
200 V	±210.000000	1 μV	10 MΩ ±1%	0.5 + 0.08	5 + 0.4	14 + 2	22 + 2	30 + 2	1.5 + 0.3
1000 V ¹³	±1100.000000	10 μV	10 MΩ ±1%	1 + 0.05	5 + 0.08	14 + 0.4	22 + 0.4	30 + 0.4	1.5 + 0.06

DC Voltage Uncertainty = ±[(ppm of reading) × (measured value) + (ppm of range) × (range used)] / 1,000,000.

% Accuracy = (ppm accuracy) / 10,000.

1ppm of Range = 20 counts for ranges up to 200V and 10 counts on 1000V range at 7½ digits.

Normal Accuracy¹⁴ – 1PLC, DFILT off

Range	Full Scale	Resolution	Input Resistance	24 Hours ²	Relative Accuracy ±(ppm of reading + ppm of range)			2 Years ³	Temperature Coefficient ±(ppm of reading + ppm of range)/°C Outside T _{Cal} ±5°C
					90 Days ³	1 Year ³	2 Years ³		
200 mV ⁴	±210.000000	10 nV	>100 GΩ	3.5 + 6	15 + 11	19 + 12	23 + 13	2 + 1.8	
2 V ⁴	±2.10000000	100 nV	>100 GΩ	1.2 + 0.6	6 + 1.1	10 + 1.2	14 + 1.3	0.2 + 0.18	
20 V	±21.00000000	1 μV	>100 GΩ	3.2 + 0.35	8 + 0.4	12 + 0.4	16 + 0.4	0.3 + 0.02	
200 V	±210.000000	10 μV	10 MΩ ±1%	5 + 1.2	14 + 2.8	22 + 2.8	30 + 2.8	1.5 + 0.3	
1000 V ¹³	±1100.0000	100 μV	10 MΩ ±1%	5 + 0.4	14 + 0.7	22 + 0.7	30 + 0.7	1.5 + 0.06	

Speed and Accuracy 90 Days

Range	Accuracy ^{1,5} ±(ppm of reading + ppm of range + ppm of range rms noise ¹⁰)											
	10PLC DFILT On, 10 Readings		10PLC DFILT Off		1PLC DFILT On, 10 Readings		1PLC DFILT Off		0.1PLC DFILT Off		0.01PLC ¹¹ DFILT Off	
	200 mV ⁴	15 + 8	+ 0	15 + 8	+ 0.5	15 + 8	+ 0.7	15 + 8	+ 1	25 + 10	+ 13	100 + 200
2 V ⁴	6 + 0.8	+ 0	6 + 0.8	+ 0.05	6 + 0.8	+ 0.07	6 + 0.8	+ 0.1	7 + 1	+ 1.3	130 + 200	+ 3
20 V	6 + 0.15	+ 0	6 + 0.15	+ 0.03	7 + 0.15	+ 0.05	8 + 0.15	+ 0.08	15 + 0.5	+ 0.7	130 + 200	+ 3
200 V	14 + 2	+ 0	14 + 2	+ 0.1	14 + 2	+ 0.15	14 + 2	+ 0.25	15 + 2	+ 1	130 + 200	+ 3
1000 V ¹³	14 + 0.4	+ 0	14 + 0.4	+ 0.05	14 + 0.4	+ 0.05	14 + 0.4	+ 0.1	15 + 0.5	+ 0.5	90 + 200	+ 2

PLC = Power Line Cycles. DFILT = Digital Filter.

Noise Rejection (dB)⁸

Speed (Number of Power Line Cycles)	AC and DC CMRR ⁶		AC NMRR		
	Line Sync On ⁷	Internal Trigger	Line Sync On ⁷	Line Sync On ⁷	Internal Trigger
			25 Readings DFILT On	DFILT Off	DFILT Off
PLC ≥ 1	140	120	90	80	60
PLC < 1	90	60	60	50	0

Effective noise is reduced by a factor of 10 for every 20dB of noise rejection (140dB reduces effective noise by 10,000,000:1).

CMRR is rejection of undesirable AC or DC signal between LO and earth. NMRR is rejection of undesirable power line related AC signal between HI and LO.

Keithley Factory Calibration Uncertainty

Range	ppm of reading
200 mV	3.2
2 V	3.2
20 V	2.6
200 V	2.6
1000 V	2.6

Factory calibration uncertainty represents traceability to NIST. This uncertainty is added to relative accuracy specifications to obtain absolute accuracies. The 200mV and 2V range uncertainties are equal to the uncertainty of the 2V calibration source. The 20V, 200V, and 1000V range uncertainties are equal to the uncertainty of the 20V calibration source.

DCV Reading Rates^{9,10}

PLC	Measurement Aperture	Bits	Default Digits	Readings/Second to Memory		Readings/Second to IEEE-488 ¹⁵		Readings/Second with Time Stamp to IEEE-488 ¹⁵	
				Autozero Off	Autozero On	Autozero Off	Autozero On	Autozero Off	Autozero On
10	167 ms (200 ms)	29	8½	6 (5)	2 (1.7)	6 (5)	2 (1.6)	6 (5)	2 (1.6)
2	33.4 ms (40 ms)	27	7½	29 (25)	9 (7.6)	29 (24)	9 (7.4)	27 (22)	9 (7.4)
1	16.7 ms (20 ms)	26	7½	56 (48)	47 (40)	55 (45)	46 (38)	50 (41)	42 (34)
0.2	3.34 ms (4 ms)	23	6½	235 (209)	154 (137)	225 (200)	146 (130)	152 (135)	118 (105)
0.1	1.67 ms (2 ms)	22	6½	318 (305)	173 (166)	308 (295)	168 (161)	181 (174)	121 (116)
0.02	334 μs (400 μs)	20	5½	325 (325)	179 (179)	308 (308)	173 (173)	182 (182)	124 (124)
0.01	167 μs (167 μs)	19	4½	390 (390)	186 (186)	365 (365)	182 (182)	201 (201)	125 (125)
0.01 ¹¹	167 μs (167 μs)	19	4½	2000(2000)		2000(2000)			

DC Volts (cont'd)

Linearity	<0.1ppm of range typical, <0.2ppm maximum.		Polarity Reversal Error	This is the portion of the instrument error that is seen when HI and LO are reversed. This is not an additional error—it is included in the overall instrument accuracy specification. Reversal Error: <4 counts at 10V input at 7½ digits, 10 power line cycles, synchronous autozero, 10-reading repeat digital filter.
Zero Stability	Typical maximum variation in 1 hour, T _{REF} ± 0.5°C, 7½-digit resolution, 10-reading digital filter, synchronous autozero.		Input Bias Current	<100pA at 25°C.
	Range	1 PLC	10 PLC	Settling Characteristics
	200 mV ⁴	± 60 counts	± 40 counts	<50µs to 10ppm of step size for the 200mV–20V ranges. <1ms to 10ppm of step size for the 200V and 1000V ranges. Reading settling times are affected by source impedance and cable dielectric absorption characteristics.
	2 V ⁴	± 6 counts	± 4 counts	Autorangeing
	20 V	± 4 counts	± 1 count	Autorange up at 105% of range, down at 10% of range.
	200 V	± 5 counts	± 2 counts	
	1000 V	± 2 counts	± 1 count	

DC Volts Notes

- Specifications are for 10 power line cycles, synchronous autozero, 10-reading repeat digital filter, autorange off, except as noted.
- For T_{CAL} ± 1°C, following 4-hour warm-up. T_{CAL} is ambient temperature at calibration (23°C at the factory). Add 0.5 ppm of reading uncertainty if the unit is power cycled during this interval.
- For T_{CAL} ± 5°C, following 4-hour warm-up.
- Care must be taken to minimize thermal offsets due to operator cables.
- For T_{CAL} ± 5°C, normal autozero. 1-year or 2-year accuracy can be found by applying the same speed accuracy ppm changes to the 1-year or 2-year base accuracy.
- Applies for 1kΩ imbalance in the LO lead. For 400Hz operation, subtract 10dB. For the 200V and 1000V ranges, subtract 20dB.
- For noise synchronous to the line frequency.
- For line frequency ± 0.1%.
- For on-scale readings, no trigger delays, internal trigger, digital filter off, normal autozero, display off, SREAL format. These rates are for 60Hz and (50Hz). Rates for 400Hz equal those for 50Hz.
- Typical values. Peak-to-peak noise equals 6 times rms noise.
- In burst mode, display off. Burst mode requires autozero refresh (by changing resolution or measurement function) once every 24 hours.
- Specifications apply for 20-reading repeat digital filter, T_{REF} ± 0.5°C (T_{REF} is the initial ambient temperature), and for measurements within 10% of the initial measurement value and within 10 minutes of the initial measurement time.
- Add 2.5ppm × (V_{IN}/1000V)² additional uncertainty for inputs above 200V, except in transfer accuracy specifications.
- Specifications are for 1 power line cycle, normal autozero, digital filter off, autorange off.
- Using Internal Buffer.

DCV Peak Spikes Measurement

Repetitive Spikes Accuracy ¹		90 Days, 1 Year or 2 Years, T _{CAL} ± 5°C								Temperature Coefficient	
Range	0–1kHz ²	1kHz–10kHz	10kHz–30kHz	30kHz–50kHz	50kHz–100kHz	100kHz–300kHz	300kHz–500kHz	500kHz–750kHz	750kHz–1MHz	±(% of reading+ % of range)/°C	Outside T _{CAL} ± 5°C
200 mV	0.08+0.7	0.09+0.7	0.1 +0.7	0.15+0.7	0.25+0.7	1.0+0.7	2.5+0.7	5.5+0.7	9+0.7		0.002+0.03
2 V	0.08+0.3	0.09+0.3	0.1 +0.3	0.15+0.3	0.25+0.3	1.0+0.3	2.5+0.3	5.5+0.3	9+0.3		0.002+0.03
20 V	0.1 +0.7	0.11+0.7	0.14+0.7	0.19+0.7	0.25+0.7	1.0+0.7	2.5+0.7	5.5+0.7	9+0.7		0.004+0.03
200 V ³	0.1 +0.3	0.11+0.3	0.14+0.3	0.19+0.3	0.25+0.3	1.0+0.3 ²	2.5+0.3 ²	5.5+0.3 ²	9+0.3 ²		0.004+0.03
1000 V ³	0.12+0.6	0.16+0.6	0.2 +0.6	0.25+0.6 ²	0.5 +0.6 ²						0.01 +0.02
Max. % of Range	±125%	±125%	±125%	±125%	±125%	±125%	±125%	±100%	±75%		

Default Measurement Resolution

3½ digits.

Maximum Input

±1100V peak value, 2×10⁷V·Hz (for inputs above 20V).

Non-Repetitive Spikes

10% of range per µs typical slew rate.

Spike Width

Specifications apply for spikes ≥ 1µs.

Range Control

In Multiple Display mode, voltage range is the same as DCV range.

Spikes Measurement Window

Default is 100ms per reading (settable from 0.1 to 9.9s in Primary Display mode).

Input Characteristics

Same as ACV input characteristics.

Spikes Display

Access as multiple display on DC Volts. First option presents positive peak spikes and highest spike since reset. Second option presents negative spikes and lowest spike. Highest and lowest spike can be reset by pressing DCV function button. Third option displays the maximum and minimum levels of the input signal. Spikes displays are also available through CONFIG-ACV-ACTYPE as primary displays.

DCV Peak Spikes Notes

- Specifications apply for 10-reading digital filter. If no filter is used, add 0.25% of range typical uncertainty.
- Typical values.
- Add 0.001% of reading × (V_{IN}/100V)² additional uncertainty for inputs above 100V.
- Specifications assume AC+DC coupling for frequencies below 200Hz. Below 20Hz add 0.1% of reading additional uncertainty.

AC Volts

AC magnitude: rms or Average. Peak and Crest Factor measurements also available.

ACV Input Characteristics

rms Range	Peak Input	Full Scale rms	Resolution	Input Impedance	Temperature Coefficient ² ±(% of reading + % of range) / °C Outside T _{CAL} ±5°C
200 mV	1 V	210.0000	100 nV	1MΩ ±2% with <140pF	0.004 + 0.001
2 V	8 V	2.100000	1 μV	1MΩ ±2% with <140pF	0.004 + 0.001
20 V	100 V	21.000000	10 μV	1MΩ ±2% with <140pF	0.006 + 0.001
200 V	800 V	210.0000	100 μV	1MΩ ±2% with <140pF	0.006 + 0.001
750 V	1100 V	775.0000	1 mV	1MΩ ±2% with <140pF	0.012 + 0.001

AC Voltage Uncertainty = ±[(% of reading) × (measured value) + (% of range) × (range used)] / 100.
 PPM Accuracy = (% accuracy) × 10,000.
 0.015% of Range = 30 counts for ranges up to 200V and 113 counts on 750V range at 5½ digits.

Low Frequency Mode rms¹

Range	1–10Hz ⁵	10–50Hz	50–100Hz	0.1–2kHz	2–10kHz	10–30kHz	30–50kHz	50–100kHz	100–200kHz	0.2–1MHz	1–2MHz
200 mV	0.09+0.015	0.06+0.015	0.035+0.015	0.03+0.01	0.02+0.01	0.025+0.01	0.05+0.01	0.3+0.015	0.75+0.025	2+0.1	5+0.2
2 V	0.09+0.015	0.04+0.015	0.025+0.015	0.02+0.01	0.02+0.01	0.025+0.01	0.05+0.01	0.3+0.015	0.75+0.025	2+0.1	5+0.2
20 V	0.1 +0.015	0.06+0.015	0.035+0.015	0.03+0.015	0.04+0.015	0.05 +0.015	0.07+0.015	0.3+0.015	0.75+0.025	4+0.2	7+0.2 ⁵
200 V ⁴	0.1 +0.015	0.05+0.015	0.03 +0.015	0.03+0.015	0.04+0.015	0.05 +0.015	0.07+0.015	0.3+0.015	0.75+0.025 ⁵	4+0.2 ⁵	
750 V ⁴	0.13+0.015	0.09+0.015	0.05 +0.015	0.05+0.015	0.06+0.015	0.08 +0.015	0.1 +0.015 ⁵	0.5+0.015 ⁵			

Normal Mode rms¹

Range	20–50Hz	50–100Hz	0.1–2kHz	2–10kHz	10–30kHz	30–50kHz	50–100kHz	100–200kHz	0.2–1MHz	1–2MHz
200 mV	0.25+0.015	0.07+0.015	0.02+0.01	0.02+0.01	0.025+0.01	0.05+0.01	0.3+0.01	0.75+0.025	2+0.1	5+0.2
2 V	0.25+0.015	0.07+0.015	0.02+0.01	0.02+0.01	0.025+0.01	0.05+0.01	0.3+0.01	0.75+0.025	2+0.1	5+0.2
20 V	0.25+0.015	0.07+0.015	0.03+0.015	0.04+0.015	0.05 +0.015	0.07+0.015	0.3+0.015	0.75+0.025	4+0.2	7+0.2 ⁵
200 V ⁴	0.25+0.015	0.07+0.015	0.03+0.015	0.04+0.015	0.05 +0.015	0.07+0.015	0.3+0.015	0.75+0.025 ⁵	4+0.2 ⁵	
750 V ⁴	0.25+0.015	0.1 +0.015	0.05+0.015	0.06+0.015	0.08 +0.015	0.1 +0.015 ⁵	0.5+0.015 ⁵			

dB Accuracy rms

Input	1–100Hz	0.1–30kHz	30–100kHz	100–200kHz	0.2–1MHz	1–2MHz
–54 to –40 dB (2 mV to 10 mV)	0.230	0.225	0.236	0.355		
–40 to –34 dB (10 mV to 20 mV)	0.036	0.031	0.041	0.088		
–34 to 6 dB (20 mV to 2 V)	0.023	0.018	0.028	0.066	0.265	0.630
6 to 26 dB (2 V to 20 V)	0.024	0.024	0.028	0.066	0.538	0.820 ⁵
26 to 46 dB (20 V to 200 V)	0.024	0.024	0.028	0.066 ⁵	0.538 ⁵	
46 to 57.8 dB (200 V to 775 V)	0.018	0.021	0.049 ⁵			

ACV Reading Rates^{5,6}

PLC	Measurement Aperture	Bits	Default Digits	Readings/Second to Memory		Readings/Second to IEEE-488 ¹²		Readings/Second with Time Stamp to IEEE-488 ¹²	
				Autozero Off	Autozero On	Autozero Off	Autozero On	Autozero Off	Autozero On
10	167 ms (200 ms)	29	6½	6 (5)	2 (1.7)	6 (5)	2 (1.6)	6 (5)	2 (1.6)
2	33.4 ms (40 ms)	27	5½	29 (25)	9 (7.6)	28 (23)	9 (7.4)	26 (21)	9 (7.4)
1	16.7 ms (20 ms)	26	5½	56 (48)	47 (40)	52 (43)	44 (36)	48 (39)	40 (33)
0.2	3.34 ms (4 ms)	23	5½	145 (129)	110 (98)	131 (117)	100 (88)	102 (91)	79 (70)
0.1	1.67 ms (2 ms)	22	5½	150 (144)	112 (108)	132 (127)	101 (97)	102 (98)	80 (77)
0.02	334 μs (400 μs)	20	5½	150 (150)	115 (115)	132 (132)	103 (103)	102 (102)	80 (80)
0.01	167 μs (167 μs)	19	4½	382 (382)	116 (116)	251 (251)	103 (103)	163 (163)	80 (80)
0.01 ⁸	167 μs (167 μs)	19	4½	2000(2000)		2000(2000)			

AC Volts (cont'd)

ACV Crest Factor Measurement ¹¹

Crest Factor	= Peak AC / rms AC.
Crest Factor Resolution	3 digits.
Crest Factor Accuracy	Peak AC uncertainty + AC normal mode rms uncertainty.
Measurement Time	100ms plus rms measurement time.
Input Characteristics	Same as ACV input.
Crest Factor Frequency Range	20Hz – 1MHz.
Crest Factor Display	Access as multiple display on AC volts.

AC Coupling

For AC only coupling, add the following % of reading:

	1–10Hz	10–20Hz	20–50Hz	50–100Hz	100–200Hz
Normal Mode (rms, average)	—	—	0.41	0.07	0.015
Low Frequency Mode (rms)	0.1	0.01	0	0	0

For low frequency mode below 200Hz, specifications apply for sine wave inputs only.

AC+DC Coupling

For DC >20% of AC rms voltage, apply the following additional uncertainty, multiplied by the ratio (DC/total rms). Applies to rms and average measurements.

	Range	% of Reading	% of Range
	200mV, 20V	0.05	0.1
	2V, 200V, 750V	0.07	0.01

Average ACV Measurement

Normal mode rms specifications apply from 10% to 100% of range, for 20Hz–1MHz. Add 0.025% of range uncertainty for 50kHz–100kHz, 0.05% of range uncertainty for 100kHz–200kHz, and 0.5% of range uncertainty for 200kHz–1MHz.

High Crest Factor Additional Error ± (% of reading)

Applies to rms measurements.

Crest Factor	1 – 2	2 – 3	3 – 4	4 – 5
Additional Error	0	0.1	0.2	0.4

ACV Peak Value Measurement ¹⁰

Repetitive Peak Accuracy, ±(% of reading+% of range), 90 Days, 1 Year or 2 Years, T_{CAL} ±5°C

Range	20Hz–	1kHz–	10kHz–	30kHz–	50kHz–	100kHz–	300kHz–	500kHz–	750kHz–	Temperature Coefficient ±(% of reading+% of range)/°C Outside T _{CAL} ±5°C
	1kHz ⁹	10kHz	30kHz	50kHz	100kHz	300kHz	500kHz	750kHz	1MHz	
200 mV	0.08+0.7	0.09+0.7	0.1 +0.7	0.15+0.7	0.25+0.7	1.0+0.7	2.5+0.7	5.5+0.7	9+0.7	0.002 + 0.03
2 V	0.08+0.3	0.09+0.3	0.1 +0.3	0.15+0.3	0.25+0.3	1.0+0.3	2.5+0.3	5.5+0.3	9+0.3	0.002 + 0.03
20 V	0.1 +0.7	0.11+0.7	0.14+0.7	0.19+0.7	0.25+0.7	1.0+0.7	2.5+0.7	5.5+0.7	9+0.7	0.004 + 0.03
200 V ⁴	0.1 +0.3	0.11+0.3	0.14+0.3	0.19+0.3	0.25+0.3	1.0+0.3 ⁵	2.5+0.3 ⁵	5.5+0.3 ⁵	9+0.3 ⁵	0.004 + 0.03
750 V ⁴	0.12+0.6	0.16+0.6	0.2 +0.6	0.25+0.6 ⁵	0.5 +0.6 ⁵					0.01 + 0.02
Valid % of Range ⁷	10–400%	10–400%	10–400%	10–350%	10–350%	10–250%	10–150%	10–100%	7.5–75%	

Default Measurement

Resolution	4 digits.
Non-Repetitive Peak	10% of range per μs typical slew rate for single spikes.
Peak Width	Specifications apply for all peaks ≥1μs.
Peak Measurement Window	100ms per reading.
Maximum Input	±1100V peak, 2×10 ⁷ V·Hz (for inputs above 20V).

Settling Characteristics

Normal Mode (rms, avg.)	<300ms to 1% of step change <450ms to 0.1% of step change <500ms to 0.01% of step change
Low Frequency Mode (rms)	<5s to 0.1% of final value

Common Mode Rejection

For 1kΩ imbalance in either lead: >60dB for line frequency ±0.1%.

Maximum Volt-Hz Product

2 × 10⁷V·Hz (for inputs above 20V).

Autoranging

Autoranges up at 105% of range, down at 10% of range.

AC Volts Notes

- Specifications apply for sinewave input, AC+DC coupling, 1 power line cycle, autozero on, digital filter off, following 55-minute warm-up.
- Temperature coefficient applies to rms and average readings. For frequencies above 100kHz, add 0.01% of reading/°C to temperature coefficient.
- For 1% to 5% of range below 750V range, and for 1% to 7% of 750V range, add 0.01% of range uncertainty. For inputs from 200kHz to 2MHz, specifications apply above 10% of range.
- Add 0.001% of reading × (V_{IN}/100V)² additional uncertainty above 100V rms.
- Typical values.
- For on-scale readings, no trigger delays, internal trigger, digital filter off, normal autozero, display off, SREAL format. These rates are for 60Hz and (50Hz). Rates for 400Hz equal those for 50Hz. Applies for normal rms and average mode. Low frequency rms mode rate is typically 0.2 readings per second.
- For overrange readings 200–300% of range, add 0.1% of reading uncertainty. For 300–400% of range, add 0.2% of reading uncertainty.
- In burst mode, display off. Burst mode requires autozero refresh (by changing resolution or measurement function) once every 24 hours.
- AC peak specifications assume AC + DC coupling for frequencies below 200Hz.
- Specifications apply for 10-reading digital filter. If no filter is used, add 0.25% of range typical uncertainty.
- Subject to peak input voltage specification.
- Using Internal Buffer.

Ohms

Two-Wire and Four-Wire Ohms

Range	Full Scale	Resolution	Current Source ¹	Open Circuit ¹²	Maximum HI Lead Resistance ²	Maximum LO Lead Resistance ²	Maximum Offset Compensation ³
20 Ω	21.0000000	100 nΩ	7.2 mA	5 V	50 Ω	10 Ω	±0.2 V
200 Ω	210.000000	1 μΩ	960 μA	5 V	200 Ω	100 Ω	±0.2 V
2 kΩ	2100.00000	10 μΩ	960 μA	5 V	200 Ω	150 Ω	-0.2 V to +2 V
20 kΩ	21.0000000	100 μΩ	96 μA	5 V	1.5 kΩ	1.5 kΩ	-0.2 V to +2 V
200 kΩ	210.000000	1 mΩ	9.6 μA	5 V	1.5 kΩ	1.5 kΩ	
2 MΩ	2.10000000	10 mΩ	1.9 μA	6 V	1.5 kΩ	1.5 kΩ	
20 MΩ ⁴	21.0000000	100 mΩ	1.4 μA ¹³	14 V			
200 MΩ ⁴	210.000000	1 Ω	1.4 μA ¹³	14 V			
1 GΩ ⁴	1.05000000	10 Ω	1.4 μA ¹³	14 V			

Keithley Factory Calibration Uncertainty

Range	ppm of reading
20 Ω	29.5
200 Ω	7.7
2 kΩ	6.4
20 kΩ	7.8
200 kΩ	7.3
2MΩ	14.9
20MΩ	14.9
200MΩ	14.9
1 GΩ	14.9

Factory calibration uncertainty represents traceability to NIST. This uncertainty is added to relative accuracy specifications to obtain absolute accuracies.

The 20Ω-2MΩ range uncertainties are equal to the uncertainty of the respective calibration sources.

The 20MΩ, 200MΩ, and 1GΩ range uncertainties are equal to the uncertainty of the 2MΩ calibration source.

Enhanced Accuracy⁵ 10PLC, Offset comp. on, DFILT 10

Range	Transfer ¹⁴	Relative Accuracy ± (ppm of reading + ppm of range)				Temperature Coefficient ± (ppm of reading + ppm of range) / °C Outside T _{cal} ±5°C
		24 Hours ⁶	90 Days ⁷	1 Year ⁷	2 Years ⁷	
20 Ω	2.5 + 3	5 + 4.5	15 + 6	17 + 6	20 + 6	2.5 + 0.7
200 Ω	2.5 + 2	5 + 3	15 + 4	17 + 4	20 + 4	2.5 + 0.5
2 kΩ	1.3 + 0.2	2.5 + 0.3	7 + 0.4	9 + 0.4	11 + 0.4	0.8 + 0.05
20 kΩ	1.3 + 0.2	2.5 + 0.3	7 + 0.4	9 + 0.4	11 + 0.4	0.8 + 0.05
200 kΩ	2.5 + 0.4	5.5 + 0.5	29 + 0.8	35 + 0.9	40 + 1	3.5 + 0.18
2MΩ	5 + 0.2	12 + 0.3	53 + 0.5	65 + 0.5	75 + 0.5	7 + 0.1
20MΩ ⁴	15 + 0.1	50 + 0.2	175 + 0.6	250 + 0.6	300 + 0.6	20 + 0.1
200MΩ ⁴	50 + 0.5	150 + 1	500 + 3	550 + 3	600 + 3	80 + 0.5
1 GΩ ⁴	250 + 2.5	750 + 5	2000 + 15	2050 + 15	2100 + 15	400 + 2.5

Resistance Uncertainty = ±[(ppm of reading) × (measured value) + (ppm of range) × (range used)] / 1,000,000.

% Accuracy = (ppm accuracy) / 10,000.

1ppm of Range = 20 counts for ranges up to 200MΩ and 10 counts on 1GΩ range at 7½ digits.

Speed and Accuracy 90 Days

RANGE	Accuracy ^{9,15} ±(ppm of reading+ppm of range+ppm of range rms noise ¹²)					
	10PLC DFILT On, 10 Readings	10PLC DFILT Off	1PLC DFILT On, 10 Readings	1PLC DFILT Off	0.1PLC ¹¹ DFILT Off	0.01PLC ^{8,11} DFILT Off
20 Ω	15 + 11 + 0	15 + 11 + 0.5	15 + 13 + 0.5	15 + 13 + 1	15 + 16 + 25	110 + 200 + 35
200 Ω	15 + 8 + 0	15 + 8 + 0.5	17 + 8 + 0.5	17 + 8 + 1	17 + 10 + 15	110 + 200 + 35
2 kΩ	7 + 0.8 + 0	7 + 0.8 + 0.05	8 + 0.8 + 0.07	8 + 0.8 + 0.2	8 + 1 + 2	130 + 230 + 5
20 kΩ	7 + 0.8 + 0	7 + 0.8 + 0.1	8 + 0.8 + 0.1	9 + 0.8 + 0.2	40 + 1 + 2	130 + 230 + 5
200 kΩ	29 + 0.8 + 0	29 + 0.8 + 0.1	31 + 0.8 + 0.1	34 + 0.8 + 0.2	250 + 1 + 2	
2MΩ	53 + 0.5 + 0	53 + 0.5 + 0.1	58 + 0.5 + 0.1	68 + 0.5 + 0.2	750 + 0.7 + 2	
20MΩ ⁴	175 + 0.6 + 0	175 + 0.6 + 0	175 + 0.6 + 0	200 + 0.6 + 0		
200MΩ ⁴	500 + 3 + 0	510 + 3 + 0	510 + 3 + 0	550 + 3 + 0		
1 GΩ ⁴	2000 + 15 + 0	2100 + 15 + 0	2100 + 15 + 0	2500 + 15 + 0		

PLC = Power Line Cycles. DFILT = Digital Filter.

2-Wire Accuracy ±(ppm of range)

Range	Additional Uncertainty (inside T _{cal} ± 5°C)	Temperature Coefficient (outside T _{cal} ± 5°C)
20 Ω	300 ppm	70 ppm/°C
200 Ω	30 ppm	7 ppm/°C
2 kΩ	3 ppm	0.7 ppm/°C

Normal Accuracy¹⁵ 1PLC, Offset comp. off, DFILT off

RANGE	Relative Accuracy ± (ppm of reading + ppm of range)				Temperature Coefficient ± (ppm of reading + ppm of range) / °C Outside T _{cal} ± 5°C
	24 Hours ⁶	90 Days ⁷	1 Year ⁷	2 Years ⁷	
20 Ω	5 + 12	15 + 16	17 + 17	20 + 19	2.5 + 2.5
200 Ω	7 + 8	17 + 11	19 + 12	22 + 13	2.5 + 1.8
2 kΩ	3.5 + 1.1	8 + 1.4	10 + 1.5	12 + 1.6	0.8 + 0.18
20 kΩ	4.5 + 1.1	9 + 1.4	11 + 1.5	13 + 1.6	0.8 + 0.18
200 kΩ	11 + 1.1	34 + 1.4	40 + 1.5	45 + 1.6	3.5 + 0.18
2 MΩ	27 + 0.9	68 + 1.1	80 + 1.1	90 + 1.1	7 + 0.1
20 MΩ ⁴	75 + 0.2	200 + 0.6	275 + 0.6	325 + 0.6	20 + 0.1
200 MΩ ⁴	200 + 1	550 + 3	600 + 3	650 + 3	80 + 0.5
1 GΩ ⁴	1250 + 5	2500 + 15	2550 + 15	2600 + 15	400 + 2.5

Ohms (cont'd)

Settling Characteristics	Pre-programmed settling delay times are for <500pF external circuit capacitance. Reading settling times are affected by source impedance and cable dielectric absorption characteristics.
Ohms Voltage Drop Measurement	Available as a multiple display.
Autoranging	Autoranges up at 105% of range, down at 10% of range.

2-Wire Resistance Reading Rates^{10,12}

PLC	Measurement Aperture	Bits	Default Digits	Readings/Second to Memory		Readings/Second to IEEE-488 ¹⁶		Readings/Second with Time Stamp to IEEE-488 ¹⁶	
				Autozero Off	Autozero On	Autozero Off	Autozero On	Autozero Off	Autozero On
10	167 ms (200 ms)	29	8½	6 (5)	2 (1.7)	6 (5)	2 (1.6)	6 (5)	2 (1.6)
2	33.4 ms (40 ms)	27	7½	29 (25)	9 (7.6)	29 (24)	9 (7.4)	27 (22)	9 (7.4)
1	16.7 ms (20 ms)	26	7½	56 (48)	47 (40)	55 (45)	46 (38)	50 (41)	42 (34)
0.2 ¹¹	3.34 ms (4 ms)	23	6½	222 (197)	156 (139)	220 (196)	148 (132)	156 (139)	107 (95)
0.1 ¹¹	1.67 ms (2 ms)	22	6½	330 (317)	176 (169)	305 (293)	166 (159)	157 (151)	110 (106)
0.02 ¹¹	334 µs (400 µs)	20	5½	330 (330)	182 (182)	305 (305)	172 (172)	160 (160)	113 (113)
0.01 ¹¹	167 µs (167 µs)	19	4½	384 (384)	186 (186)	352 (352)	172 (172)	179 (179)	123 (123)
0.01 ^{8,11}	167 µs (167 µs)	19	4½	2000(2000)		2000(2000)			

4-Wire Resistance Reading Rates^{10,12}

PLC	Measurement Aperture	Bits	Default Digits	Readings or Readings with Time Stamp/Second to Memory or IEEE-488 ¹⁶			
				Autozero Off Offset Comp. Off	Autozero On Offset Comp. On	Autozero Off Offset Comp. Off	Autozero On Offset Comp. On
10	167 ms (200 ms)	29	8½	6 (5)	3 (2.5)	2 (1.6)	1 (0.8)
2	33.4 ms (40 ms)	27	7½	27 (22)	13 (10.7)	9 (7.4)	4 (3.5)
1	16.7 ms (20 ms)	26	7½	50 (41)	25 (20)	42 (34)	20 (16)
0.2 ¹¹	3.34 ms (4 ms)	23	6½	154 (137)	76 (68)	115 (102)	54 (48)
0.1 ¹¹	1.67 ms (2 ms)	22	6½	184 (176)	92 (88)	123 (118)	63 (60)
0.02 ¹¹	334 µs (400 µs)	20	5½	186 (186)	107 (107)	126 (126)	72 (72)
0.01 ¹¹	167 µs (167 µs)	19	4½	211 (211)	107 (107)	133 (133)	72 (72)

Ohms Notes

- Current source has an absolute accuracy of $\pm 5\%$.
- Refers to source lead resistance. Sense lead resistance is limited only by noise considerations. For best results, it is suggested that it be limited to 1.5kΩ.
- Offset compensation voltage plus source current times measured resistance must be less than source current times resistance range selected.
- For 2-wire mode.
- Specifications are for 10 power line cycles, 10-reading repeat digital filter, synchronous autozero, autorange off, 4-wire mode, offset compensation on (for 20Ω to 20kΩ ranges), except as noted.
- For $T_{CAL} \pm 1^\circ\text{C}$, following 4-hour warm-up. T_{CAL} is ambient temperature at calibration (23°C at the factory).
- For $T_{CAL} \pm 5^\circ\text{C}$, following 4-hour warm-up.
- In burst mode, display off. Burst mode requires autozero refresh (by changing resolution or measurement function) once every 24 hours.
- For $T_{CAL} \pm 5^\circ\text{C}$, normal autozero. 1-year and 2-year accuracy can be found by applying the same speed accuracy ppm changes to the 1-year or 2-year base accuracy.
- For on-scale readings, no trigger delays, digital filter off, internal trigger, normal autozero, display off, SREAL format. These rates are for 60Hz and (50Hz). Rates for 400Hz equal those for 50Hz.
- Ohms measurements at rates lower than 1 power line cycle are subject to potential noise pickup. Care must be taken to provide adequate shielding.
- Typical values. Peak-to-peak noise equals 6 times rms noise.
- Current source is paralleled with a 10MΩ resistance.
- Specifications apply for 20-reading repeat digital filter, $T_{REF} \pm 0.5^\circ\text{C}$ (T_{REF} is the initial ambient temperature), and for measurements within 10% of the initial measurement value and within 10 minutes of the initial measurement time.
- Specifications are for 1 power line cycle, normal autozero, digital filter off, autorange off, 4-wire mode, offset compensation off, except as noted.
- Using Internal Buffer.

DC Amps

DCI Input Characteristics and Accuracy

Range	Full Scale	Resolution	Maximum Burden Voltage ⁶	Relative Accuracy ¹ ±(ppm of reading + ppm of range)				Temperature Coefficient ¹ ±(ppm of reading + ppm of range)/°C Outside $T_{CAL} \pm 5^\circ\text{C}$
				24 Hours ²	90 Days ³	1 Year ³	2 Years ³	
200 µA	210.00000	10 pA	0.25 V	50 + 6	275 + 25	350 + 25	500 + 25	50 + 5
2 mA	2.1000000	100 pA	0.3 V	50 + 5	275 + 20	350 + 20	500 + 20	50 + 5
20 mA	21.000000	1 nA	0.35 V	50 + 5	275 + 20	350 + 20	500 + 20	50 + 5
200 mA	210.00000	10 nA	0.35 V	75 + 5	300 + 20	375 + 20	525 + 20	50 + 5
2 A	2.1000000	100 nA	1.1 V	350 + 5	600 + 20	750 + 20	1000 + 20	50 + 5

DC Current Uncertainty = $\pm [(\text{ppm reading}) \times (\text{measured value}) + (\text{ppm of range}) \times (\text{range used})] / 1,000,000$.

% Accuracy = (ppm accuracy) / 10,000.

5ppm of Range = 10 counts at 6½ digits.

DC Amps (cont'd)

DCI Reading Rates^{4,5}

PLC	Measurement Aperture	Bits	Default Digits	Readings/Second to Memory		Readings/Second to IEEE-488 ⁹		Readings/Second with Time Stamp to IEEE-488 ⁹	
				Autozero Off	Autozero On	Autozero Off	Autozero On	Autozero Off	Autozero On
10	167 ms (200 ms)	29	7½	6 (5)	2 (1.7)	6 (5)	2 (1.6)	6 (5)	2 (1.6)
2	33.4 ms (40 ms)	27	7½	29 (25)	9 (7.6)	29 (24)	9 (7.4)	27 (22)	9 (7.4)
1	16.7 ms (20 ms)	26	6½	56 (48)	47 (40)	55 (45)	46 (38)	50 (41)	42 (34)
0.2	3.34 ms (4 ms)	23	6½	222 (197)	157 (140)	209 (186)	150 (133)	156 (139)	113 (100)
0.1	1.67 ms (2 ms)	22	5½	334 (321)	178 (171)	310 (298)	168 (161)	186 (178)	124 (119)
0.02	334 μs (400 μs)	20	5½	334 (334)	184 (184)	310 (310)	174 (174)	187 (187)	127 (127)
0.01	167 μs (167 μs)	19	4½	387 (387)	186 (186)	355 (355)	176 (176)	202 (202)	128 (128)
0.01 ⁷	167 μs (167 μs)	19	4½	2000 (2000)		2000 (2000)			

Speed and Accuracy

90 Days

ACCURACY^{1,8}

±(ppm of reading+ppm of range+ppm of range rms noise⁴)

Range	1PLC		0.1PLC		0.01PLC ⁷	
	DFILT On, 10 Readings	DFILT Off	DFILT Off	DFILT Off	DFILT Off	DFILT Off
200 μA	275+25+0	275+25+0.5	300+25+50	300+200+80		
2 mA	275+20+0	275+20+0.5	300+20+50	300+200+80		
20 mA	275+20+0	275+20+0.5	300+20+50	300+200+80		
200 mA	300+20+0	300+20+0.5	325+20+50	325+200+80		
2 A	600+20+0	600+20+0.5	625+20+50	625+200+80		

PLC = Power Line Cycles. DFILT = Digital Filter.

Keithley Factory Calibration Uncertainty

Range	ppm of reading
200 μA	43
2 mA	40
20 mA	55
200 mA	162
2 A	129

Factory calibration uncertainty represents traceability to NIST. This uncertainty is added to relative accuracy specifications to obtain absolute accuracies. The uncertainties for each range are equal to the uncertainty of the respective calibration sources.

Settling Characteristics	<500μs to 50ppm of step size. Reading settling times are affected by source impedance and cable dielectric absorption characteristics.
Maximum Allowable Input	2.1A, 250V.
Overload Protection	2A fuse (250V), accessible from front (for front input) and rear (for rear input).
Autoranging	Autoranges up at 105% of range, down at 10% of range.

DC Amps Notes

- Specifications are for 1 power line cycle, autozero on, 10-reading repeat digital filter.
- For $T_{CAL} \pm 1^{\circ}C$, following 55-minute warm-up. T_{CAL} is ambient temperature at calibration ($23^{\circ}C$ at the factory).
- For $T_{CAL} \pm 5^{\circ}C$, following 55-minute warm-up.
- Typical values. Peak-to-peak noise equals 6 times rms noise.
- For on-scale readings, no trigger delays, internal trigger, digital filter off, normal autozero, display off, SREAL format. These rates are for 60Hz and (50Hz). Rates for 400Hz equal those for 50Hz.
- Actual maximum burden voltage = (maximum burden voltage) × (I MEASURED/I FULL SCALE).
- In burst mode, display off. Burst mode requires autozero refresh (by changing resolution or measurement function) once every 24 hours.
- For $T_{CAL} \pm 5^{\circ}C$, normal autozero. 1-year and 2-year accuracy can be found by applying the same speed accuracy ppm changes to the 1-year or 2-year base accuracy.
- Using Internal Buffer.

DC In-Circuit Current

Measurement Range Chart

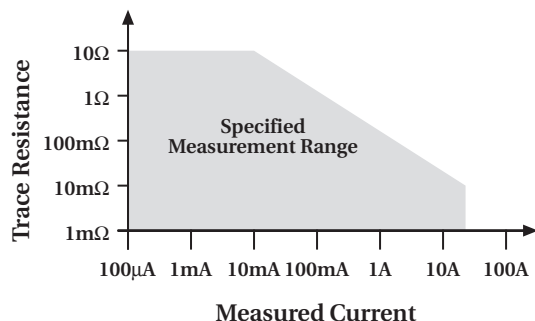

The DC in-circuit current measurement function allows a user to measure the current through a wire or a circuit board trace without breaking the circuit.

When the In-Circuit Current Measurement function is selected, the 2002 will first perform a 4-wire resistance measurement, then a voltage measurement, and will display the calculated current.

TYPICAL RANGES

Current	100μA to 12A.
Trace Resistance	1mΩ to 10Ω.
Voltage	±200mV max. across trace.
Speed	4 measurements/second at 1 power line cycle.
Accuracy	±(5% + 500μA). For 1 power line cycle, autozero on, 10-reading digital filter, $T_{CAL} \pm 5^{\circ}C$, 90 days, 1 year or 2 years.

AC Amps

AC magnitude: rms or Average.

ACI Input Characteristics

rms Range	Peak Input	Full Scale rms	Resolution	Maximum Burden Voltage ⁵	Temperature Coefficient ±(% of reading + % of range)/°C Outside T _{CAL} ±5°C
200 µA	1 mA	210.0000	100 pA	0.35 V	0.01 + 0.001
2 mA	10 mA	2.100000	1 nA	0.45 V	0.01 + 0.001
20 mA	100 mA	21.00000	10 nA	0.5 V	0.01 + 0.001
200 mA	1 A	210.0000	100 nA	0.5 V	0.01 + 0.001
2 A	2 A	2.100000	1 µA	1.5 V	0.01 + 0.001

ACI Accuracy^{1,2} 90 Days, 1 Year or 2 Years, T_{CAL} ±5°C, for 5% to 100% of range, ±(% of reading + % of range)

Range	20Hz–50Hz	50Hz–200Hz	200Hz–1kHz	1kHz–10kHz	10kHz–30kHz ³	30kHz–50kHz ³	50kHz–100kHz ³
200 µA	0.35 + 0.015	0.2 + 0.015	0.4 + 0.015	0.5 + 0.015			
2 mA	0.3 + 0.015	0.15 + 0.015	0.12 + 0.015	0.12 + 0.015	0.25 + 0.015	0.3 + 0.015	0.5 + 0.015
20 mA	0.3 + 0.015	0.15 + 0.015	0.12 + 0.015	0.12 + 0.015	0.25 + 0.015	0.3 + 0.015	0.5 + 0.015
200 mA	0.3 + 0.015	0.15 + 0.015	0.12 + 0.015	0.15 + 0.015	0.5 + 0.015	1 + 0.015	3 + 0.015
2 A	0.35 + 0.015	0.2 + 0.015	0.3 + 0.015	0.45 + 0.015	1.5 + 0.015	4 + 0.015	

AC Current Uncertainty = ±[(% of reading) × (measured value) + (% of range) × (range used)] / 100.

ppm Accuracy = (% accuracy) × 10,000.

0.015% of Range = 30 counts at 5½ digits.

ACI Reading Rates^{3,4}

PLC	Measurement Aperture	Bits	Default Digits	Readings/Second to Memory		Readings/Second to IEEE-488 ⁷		Readings/Second with Time Stamp to IEEE-488 ⁷	
				Autozero Off	Autozero On	Autozero Off	Autozero On	Autozero Off	Autozero On
10	167 ms (200 ms)	29	6½	6 (5)	2 (1.7)	6 (5)	2 (1.6)	6 (5)	2 (1.6)
2	33.4 ms (40 ms)	27	5½	29 (25)	9 (7.6)	28 (23)	9 (7.4)	27 (22)	9 (7.4)
1	16.7 ms (20 ms)	26	5½	56 (48)	47 (40)	53 (43)	44 (36)	47 (38)	40 (33)
0.2	3.34 ms (4 ms)	23	5½	163 (145)	102 (91)	139 (124)	100 (89)	95 (84)	74 (66)
0.1	1.67 ms (2 ms)	22	5½	163 (156)	104 (100)	139 (133)	101 (97)	95 (91)	75 (72)
0.02	334 µs (400 µs)	20	5½	163 (163)	107 (107)	139 (139)	103 (103)	95 (95)	76 (76)
0.01	167 µs (167 µs)	19	4½	384 (384)	110 (110)	253 (253)	103 (103)	164 (164)	76 (76)
0.01 ⁶	167 µs (167 µs)	19	4½	2000(2000)		2000(2000)			

AC Coupling

For AC only coupling, add the following % of reading:

	20–50Hz	50–100Hz	100–200Hz
rms, Average	0.55	0.09	0.015

AC+DC Coupling

For DC>20% of AC rms voltage, apply the following additional uncertainty, multiplied by the ratio (DC/total rms).

	% of Reading	% of Range
rms, Average	0.05	0.1

High Crest Factor Additional Error ±(% of reading)

Applies to rms measurements.

Crest Factor	1–2	2–3	3–4	4–5
Additional Error	0	0.1	0.2	0.4

Average ACI Measurement

rms specifications apply for 10% to 100% of range.

Settling Characteristics	<300ms to 1% of step change <450ms to 0.1% of step change <500ms to 0.01% of step change
Autoranging	Autoranges up at 105% of range, down at 10% of range.

AC Amps Notes

- Specifications apply for sinewave input, AC+DC coupling, 1 power line cycle, autozero on, digital filter off, following 55-minute warm-up.
- Add 0.005% of range uncertainty for current above 0.5A rms for self-heating.
- Typical values.
- For on-scale readings, no trigger delays, digital filter off, normal autozero, display off, internal trigger, SREAL

format. These rates are for 60Hz and (50Hz). Rates for 400Hz equal those for 50Hz.

- Actual maximum burden voltage = (maximum burden voltage) × (I_{MEASURED}/I_{FULL SCALE}).
- In burst mode, display off. Burst mode requires autozero refresh (by changing resolution or measurement function) once every 24 hours.
- Using Internal Buffer.

Frequency Counter

Frequency/Period Input Characteristics and Accuracy

90 Days, 1 Year, or 2 Years

	Frequency Range ¹	Period Range	Resolution	Minimum Signal Level ²			Maximum Input	Trigger Level	Accuracy ±(% of reading)
				1Hz–1MHz	1–5MHz	5–15MHz			
AC Voltage Input	1Hz–15 MHz	67 ns – 1 s	5 digits	60 mV	60 mV	350 mV	1100 V pk ¹	0–600V	0.03
AC Current Input	1Hz– 1 MHz	1 μs – 1 s	5 digits	150 μA			1 A pk	0–600mA	0.03
Time Base	7.68MHz ± 0.01%, 0°C to 55°C.								
Reading Time	420ms maximum.								
Voltage Input Impedance	1MΩ ± 2% with <140pF.								
Trigger Level Adjustment	Trigger level is adjustable in 0.5% of range steps to ±60% of range in real-time using the up and down range buttons.								
Frequency Ranging	Autoranging from Hz to MHz.								
Frequency Coupling	AC + DC or AC only.								

Frequency Notes

- Subject to 2×10^7 V·Hz product (for inputs above 20V).
- Valid for the lowest range. For each range increase, multiply these numbers by 10.

Temperature (RTD)

Range	Resolution	24 Hours ²	4-Wire Accuracy ⁵			PLC	RTD Temperature Reading Rates ¹ (2- or 4-Wire)		
			90 Days ³	1 Year ³	2 Years ³		Readings or Readings with Time Stamp/Second to Memory or IEEE-488		
							Autozero Off		Autozero On
–100° to +100°C	0.001°C	±0.016°C	±0.020°C	±0.021°C	±0.022°C				
–200° to +630°C	0.001°C	±0.061°C	±0.066°C	±0.068°C	±0.070°C				
–148° to +212°F	0.001°F	±0.029°F	±0.036°F	±0.038°F	±0.040°F				
–328° to +1166°F	0.001°F	±0.110°F	±0.119°F	±0.122°F	±0.126°F	10	3	(2.5)	1 (0.8)
						2	12	(10)	4 (3.3)
						1	20	(16)	17 (13)
						0.1	51	(49)	41 (39)
						0.01	58	(58)	46 (46)
RTD Type	100Ω platinum, DIN 43760, 4-wire. ITS-90 (PT100, D100, F100) and IPTS-68 (PT385, PT3916).								
Sensor Current	960μA (pulsed).								
Temperature Coefficient	± 0.001°C/°C or ± 0.002°F/°C outside T _{cal} ±5°C.								
Maximum Source HI Lead Resistance	200Ω.								
Maximum Source LO Lead Resistance	100Ω.								

Temperature (Thermocouple)

Thermo-couple Type	Range	Resolution	Accuracy ⁴	TC Temperature Reading Rates ¹							
				Readings/Second to Memory Autozero			Readings/Second to IEEE-488 ⁶ Autozero			Readings/Second with Time Stamp to IEEE-488 ⁶ Autozero	
				PLC	Off	On	Off	On	Off	On	
J	–200° to + 760°C	0.001°C	±0.5°C								
K	–200° to +1372°C	0.001°C	±0.5°C								
T	–200° to + 400°C	0.001°C	±0.5°C								
E	–200° to +1000°C	0.001°C	±0.6°C	10	6	(5)	2 (1.7)	6 (5)	2 (1.6)	6 (5)	2 (1.6)
R	0° to +1768°C	0.001°C	±3 °C	2	29	(25)	9 (7.6)	29 (24)	9 (7.4)	27 (22)	9 (7.4)
S	0° to +1768°C	0.001°C	±3 °C	1	57	(48)	47 (40)	56 (46)	46 (38)	50 (41)	42 (34)
B	+350° to +1820°C	0.001°C	±5 °C	0.1	131	(126)	107 (103)	100 (96)	84 (81)	83 (80)	72 (69)
				0.01	168	(168)	112 (112)	121 (121)	89 (89)	96 (96)	74 (74)

Temperature Notes

- For on-scale readings, no trigger delays, digital filter off, display off, normal autozero, internal trigger, SREAL format. These rates are for 60Hz and (50Hz). Rates for 400Hz equal those for 50Hz. Typical values.
- For T_{cal} ± 1°C, following 4-hour warm-up.
- For T_{cal} ± 5°C, following 4-hour warm-up.
- Relative to external 0°C reference junction; exclusive of thermocouple errors. Junction temperature may be external. Applies for 90 days, 1 year or 2 years, T_{cal} ±5°C.
- Specifications are for 10 power line cycles, autozero on, 10 reading repeat digital filter, 4-wire mode. Exclusive of RTD probe errors.
- Using Internal Buffer.

Operating Speed

Function Change Speed¹

Typical delay before measurement initiation after making a function change.

From Function	To Function	Range	Time
Any except 4WΩ, Temp 4WΩ, Temp	DCV	Any	4.6 ms
		Any	7.6 ms
Any	ACV	Any	574 ms
ACV, DCV, 2WΩ, Freq 4WΩ, Temp ACI	DCI	Any	7.1 ms
		Any	10 ms
		Any	22 ms
Any	ACI	Any	523 ms
Any except 4WΩ, Temp	2WΩ	20Ω to 2kΩ	4.7 ms
		20kΩ	15 ms
		200kΩ	27 ms
		2MΩ	103 ms
		20MΩ	153 ms
		200MΩ, 1GΩ	253 ms
4WΩ, Temp	2WΩ	20Ω to 2kΩ	7.7 ms
		20kΩ	18 ms
		200kΩ	30 ms
		2MΩ	105 ms
		20MΩ	157 ms
		200MΩ, 1GΩ	256 ms
Any	4WΩ	20Ω to 2kΩ	7.7 ms
		20kΩ	18 ms
		200kΩ	30 ms
		2MΩ	105 ms
Any except ACV, ACI ACV, ACI	Freq ⁵	Any	60 ms
		Any	573 ms
Any	Temp	Any	7.6 ms

Range Change Speed¹

Typical delay before measurement initiation after making a range change.

Function	From	To	Time
DCV	Any	Any	5.2 ms
ACV	Any	Any	559 ms
DCI	Any	Any	7.6 ms
ACI	Any	Any	503 ms
2WΩ	Any	20Ω to 2kΩ	5.2 ms
	Any	20kΩ	15 ms
	Any	200kΩ	27 ms
	Any	2MΩ	103 ms
	Any	20MΩ	153 ms
	Any	200MΩ, 1GΩ	253 ms
4WΩ	Any	20Ω to 2kΩ	5.2 ms
	Any	20kΩ	15 ms
	Any	200kΩ	27 ms
	Any	2MΩ	103 ms

Trigger Speed (External Trigger or Trigger-Link)

	Autozero Off	Autozero On
Trigger Latency:	< 2 μs	1.2 ms typical
Trigger Jitter:	± 0.5 μs	

GPIB Data Formatting Transmission Time²

Format	Readings Only		Readings with Time Stamp	
	Time	Rdg./s	Time	Rdg./s
DREAL (Double precision real)	0.51 ms	1961	3.1 ms	323
SREAL (Single precision real)	0.38 ms	2632	3.3 ms	303
ASCII	6.2 ms	161	10.2 ms	98

Single Function Scan Speed³ (Internal Scanner)

TYPE	DCV (20V)		2WΩ (2kΩ)		4WΩ (2kΩ)		ACV		Freq		TC Temp		RTD Temp (2-Wire)	
	Time per Chan.	Rate (Chan./second)	Time per Chan.	Rate (Chan./second)	Time per Chan.	Rate (Chan./second)	Time per Chan.	Rate (Chan./second)	Time per Chan.	Rate (Chan./second)	Time per Chan.	Rate (Chan./second)	Time per Chan.	Rate (Chan./second)
Ratio or Delta ⁴ (2 channels)	8.2 ms	122	8.5 ms	118	18.8 ms	53								
Fast Scan (using solid state channels)	8.2 ms	122	6.3 ms	159			501 ms	2	559 ms	1.8	12.8 ms	78		
Normal Scan	14 ms	71	11.4 ms	88	14.4 ms	69	506 ms	2	564 ms	1.8	17.2 ms	58	43 ms	23

Operating Speed Notes

- For display off, 0.01 power line cycles, autorange off, digital filter off, autozero on, offset compensation off. Display on may impact time by 3% worst case. To eliminate this impact, press ENTER (hold) to freeze display.
- Using 386/33 computer, average time for 1000 readings, byte order swapped, display off.
- For on-scale readings, no trigger delays, display off, 0.01 power line cycles, autorange off, digital filter off, offset compensation off, autozero off.
- Ratio and delta functions output one value for each pair of measurements.
- Based on 100kHz input frequency.

Maximum Input Levels

	Rated Input ¹	Overload Recovery Time
HI to LO	±1100V	< 900 ms
HI Sense to LO	± 350V pk 250V rms	< 900 ms
LO Sense to LO	± 150V pk 100V rms	< 900 ms
I Input to LO	2A, ± 250V (fused)	—
HI to Earth	±1600V	< 900 ms
LO to Earth	± 500V	

Note 1: For voltages between other terminals, these ratings can be added.

IEEE-488 Bus Implementation

Implementation	IEEE-488.2, SCPI-1991.0.
Multiline Commands	DCL, LLO, SDC, GET, GTL, UNT, UNL, SPE, SPD.
Uniline Commands	IFC, REN, EOI, SRQ, ATN.
Interface Commands	SH1, AH1, T5, TE0, L4, LE0, SR1, RL1, PPO, DC1, DT1, C0, E1.

Digital I/O

Connector Type	8 pin "D" subminiature.
Input	One pin, TTL compatible.
Outputs	Four pins. Open collector, 30V maximum pull-up voltage, 100mA maximum sink current, 10Ω output impedance.
Control	Direct control by output or set real-time with limits.

Delay and Timer

Time Stamp	Resolution: 1μs. Accuracy: ±0.01% of elapsed time ± 1μs. Maximum: 2,100,000.000000 seconds (24 days, 7 hours).
Delay Time	(Trigger edge to reading initiation) Maximum: 999,999.999 seconds (11 days, 14 hours). Resolution: 1ms. Jitter: ±1ms.
Timer	(Reading initiation to reading initiation) Maximum: 999,999.999 seconds (11 days, 14 hours). Resolution: 1ms. Jitter: ±1ms.

General Specifications and Standards Compliance

Power	Voltage: 90–134V and 180–250V, universal self-selecting. Frequency: 50Hz, 60Hz, or 400Hz, self-identifying at power-up. Consumption: <55VA.
Environmental	Operating Temperature: 0°C to 50°C. Storage Temperature: –40°C to 70°C. Humidity: 80% R.H., 0°C to 35°C, per MIL-T-28800E ¹ Para 4.5.5.1.2.
Calibration	Type: Software. No manual adjustments required. Sources: 2 DC voltages, 6 resistances, and 5 DC currents. All other functions calibrated (adjusted) from these sources and a short circuit. No AC calibrator required for adjustment. Average Time to Perform: 40 minutes for comprehensive calibration, 6 minutes for AC-only calibration.
Process	MIL-STD 45662A.
Physical	Case Dimensions: 90mm high × 214mm wide × 369mm deep (3½ in. × 8½ in. × 14½ in.). Working Dimensions: From front of case to rear including power cord and IEEE-488 connector: 15.0 inches. Net Weight: <4.2kg (<9.2 lbs.). Shipping Weight: <9.1kg (<20 lbs.).
Standards	EMI/RFI: Conforms to VDE 0871B (per Vfg 1046/1984), IEC 801-2. Meets FCC part 15 Class B, CISPR-22 (EN55022). Safety: Conforms to IEC348, CAN/CSA-C22.2. No. 231, MIL-T-28800E ¹ . Designed to UL1244.
Accessories Supplied	The unit is shipped with line cord, high performance modular test leads, operator's manual, option slot cover, and full calibration data.

Note 1 For MIL-T-28800E, applies to Type III, Class 5, Style E.

Extended Memory/Non-Volatile Memory Options

Model	Size (Bytes)	DATA STORAGE			
		4½-Digit	6½-Digit with Time Stamp	Type	Setup Storage Number Type
2002	8k	2,027	404	volatile	1 non-volatile
2002/MEM1	32k	6,909	1,381	non-volatile	5 non-volatile
2002/MEM2	128k	29,908	5,980	non-volatile	10 non-volatile

These are the minimum sizes to expect.

Specifications subject to change without notice.

B

Calibration Programs

B.1 Introduction

This appendix includes programs written in BASIC and Turbo C to aid you in calibrating the Model 2002. Refer to Section 2 for more details on calibration procedures.

B.2 Computer hardware requirements

The following computer hardware is required to run the example calibration programs:

- IBM PC, AT, or compatible computer.
- Keithley KPC-488.2, KPS-488.2, or KPC-488.2AT, or CEC PC-488 IEEE-488 interface for the computer.
- Two shielded IEEE-488 connecting cables (Keithley Model 7007).

B.3 BASIC program requirements

In order to use the BASIC programs, you will need the following software:

- Microsoft QBasic (supplied with MS-DOS 5.0 or later). QuickBASIC (version 4.5 or later) or Visual BASIC for MS-DOS may also be used.

- MS-DOS version 5.0 or later (version 3.3 or later may be used if not using QBasic).
- HP-style Universal Language Driver, CECHP.EXE (supplied with Keithley and CEC interface cards listed above).

B.4 Turbo C program requirements

In order to use the Turbo C programs, you will need the following software:

- MS-DOS or PC-DOS version 3.3 or later.
- Borland Turbo C version 2.0 or later. (Other ANSI-compatible C compilers can also be used, but some program modifications may be necessary.)
- HP-style Universal Language Driver, CECHP.EXE (supplied with the Keithley and CEC interface cards listed above).

B.5 Calibration equipment

Table B-1 summarizes recommended comprehensive calibration equipment, and Table B-2 summarizes test equipment required for low-level calibration.

Table B-1
Recommended equipment for comprehensive calibration

Mfg.	Model	Description	Specifications*
Fluke	5700A	Calibrator	<p>± 5ppm basic uncertainty.</p> <p>DC Voltage: 2V: ± 7ppm 20V: ± 5ppm</p> <p>Resistance: 19Ω: ± 26ppm 190Ω: ± 17ppm 1.9kΩ: ± 11ppm 19kΩ: ± 11ppm 100kΩ: ± 13ppm 1MΩ: ± 18ppm</p> <p>DC Current: 200μA: ± 100ppm 2mA: ± 55ppm 20mA: ± 55ppm 200mA: ± 65ppm 1A: ± 110ppm</p>
Keithley	8610	Low-thermal shorting plug	

* 90-day calibrator specifications shown include total uncertainty at specified output.

Table B-2
Recommended equipment for low-level calibration

Mfg.	Model	Description	Specifications*
Fluke	5700A	Calibrator	<p>± 5ppm basic uncertainty.</p> <p>DC Voltage: ± 2V: ± 7ppm +20V: ± 5ppm +100V: ± 7ppm</p> <p>Resistance: 19Ω: ± 26ppm 190Ω: ± 17ppm 1.9kΩ: ± 11ppm 19kΩ: ± 11ppm 100kΩ: ± 13ppm 1MΩ: ± 18ppm</p> <p>DC Current: 200μA: ± 100ppm 2mA: ± 55ppm 20mA: ± 55ppm 200mA: ± 65ppm 1A: ± 110ppm</p> <p>AC Voltage: 0.5mV @ 1kHz: ± 10000ppm 5mV @ 100kHz: ± 2400ppm 200mV @ 1kHz: ± 150ppm 1.5V @ 1kHz: ± 80ppm 20V @ 1kHz: ± 80ppm 20V @ 30kHz: ± 140ppm 200V @ 1kHz: ± 85ppm 200V @ 30kHz: ± 240ppm</p> <p>AC Current: 20mA @ 1kHz: ± 160ppm</p>
Keithley	3930A or 3940	Synthesizer	2V rms @ 1Hz
Keithley	8610	Low-thermal shorting plug	

* 90-day calibrator specifications shown include total uncertainty at specified output.

B.6 General program instructions

1. With the power off, connect the Model 2002 and the calibrator to the IEEE-488 interface of the computer. Be sure to use shielded IEEE-488 cables for bus connections.
2. Turn on the computer, the Model 2002, and the calibrator. Allow the Model 2002 to warm up for at least four hours before performing calibration.
3. Make sure the Model 2002 is set for a primary address of 16. You can check or change the address as follows:
 - A. Press MENU, select GPIB, then press ENTER.
 - B. Select MODE, then press ENTER.
 - C. Select ADDRESSABLE, and press ENTER.
 - D. If the address is set correctly, press EXIT as necessary to return to normal display.
 - E. To change the address, use the cursor keys to set the address to 16, then press ENTER. Press EXIT as necessary to return to normal display.
4. Make sure the calibrator primary address is at its factory default setting of 4.
5. Make sure that the computer IEEE-488 bus driver software (CECHP.EXE) is properly initialized.
6. Enter the BASIC or Turbo C editor, and type in the desired program. Check thoroughly for errors, then save the program using a convenient filename.
7. Compile and/or run the program, and follow the prompts on the screen to perform calibration.

B.7 Unlocking calibration

In order to unlock comprehensive calibration, briefly press in on the CAL switch with the power turned on. To unlock low-level calibration, press in and hold the CAL switch while turning on the power.

B.8 Comprehensive calibration

Programs B-1 and B-2 will perform comprehensive calibration almost fully automatically using the Fluke 5700A Calibrator. Figure B-1 shows low-thermal short connections, while Figure B-2 shows calibrator connections.

B.9 Low-level calibration

Programs B-3 and B-4 perform low-level calibration using the Fluke 5700A calibrator. Refer to Figure B-1 and B-3 for low-thermal short and calibrator voltage connections. Figure B-4 shows calibrator current connections. Figure B-5 shows synthesizer connections necessary to supply the 2V AC 1Hz signal.

NOTE

Low-level calibration is not normally required in the field unless the Model 2002 has been repaired.

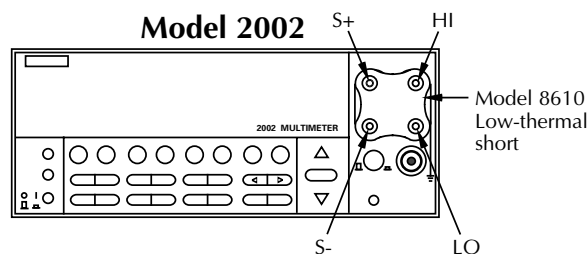

Note: Connect low-thermal short to rear panel input jacks and select rear inputs only for low-level calibration step #11.

Figure B-1
Low-thermal short connections

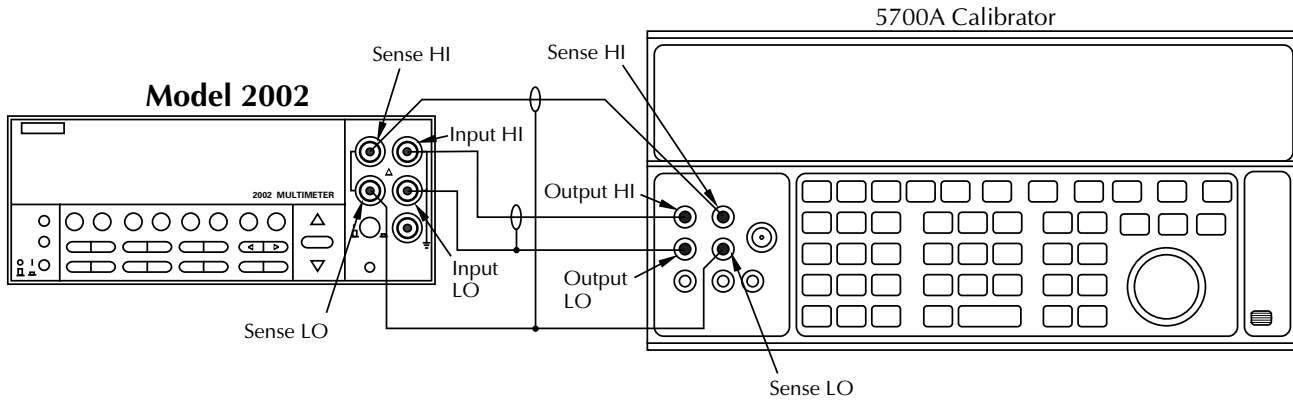

Note : Use shielded cables to minimize noise.
 Enable or disable calibrator external sense as indicated in procedure.

Figure B-2
Connections for comprehensive calibration

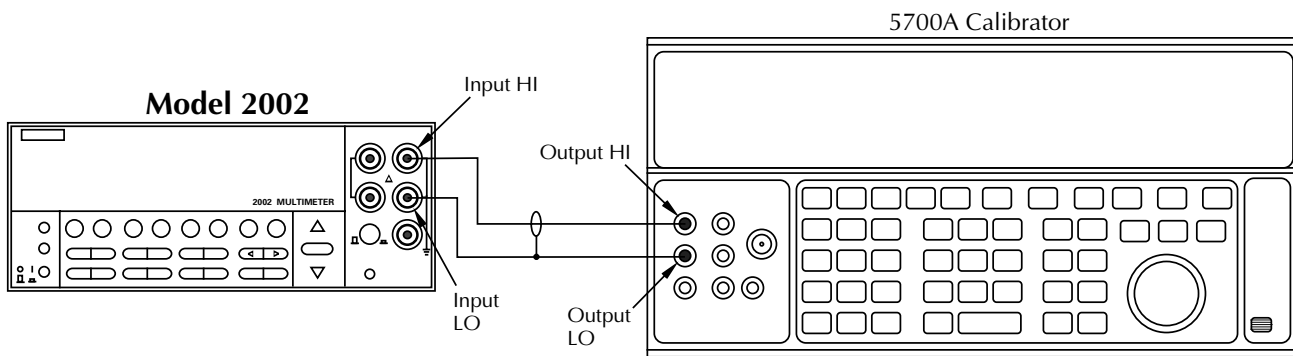
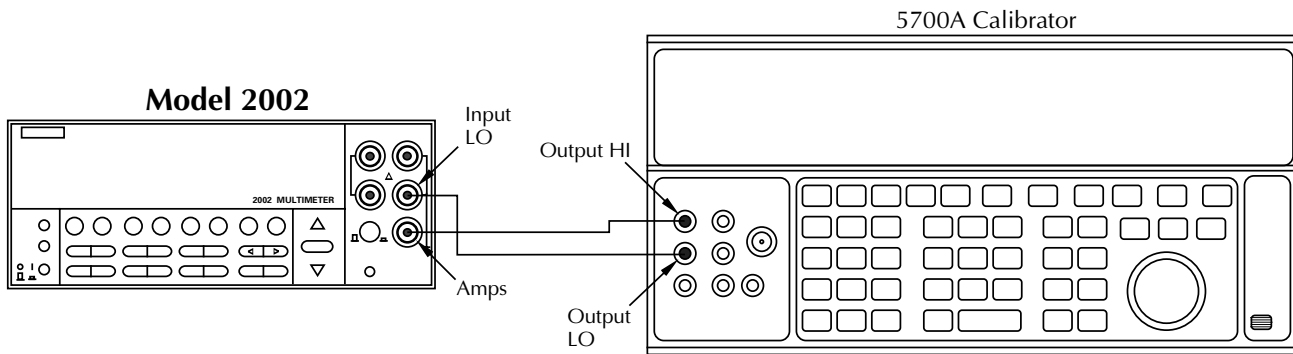

Figure B-3
Calibrator voltage connections



Note: Be sure calibrator is set for normal current output

Figure B-4
Calibrator current connections

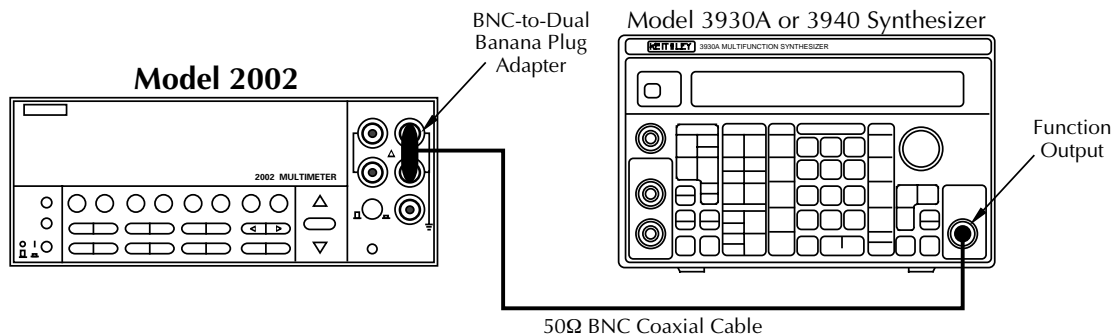

Figure B-5
Synthesizer connections

Program B-1

Comprehensive calibration program for use with Fluke 5700A Calibrator (BASIC Version)

```
' Model 2002 comprehensive calibration program for use with the
' Fluke 5700A calibrator.
' Rev. 1.2, 4/7/94
OPEN "IEEE" FOR OUTPUT AS #1          ' Open IEEE-488 output path.
OPEN "IEEE" FOR INPUT AS #2          ' Open IEEE-488 input path.
PRINT #1, "INTERM CRLF"              ' Set input terminator.
PRINT #1, "OUTTERM LF"               ' Set output terminator.
PRINT #1, "REMOTE 4 16"              ' Put 2002, 5700A in remote.
PRINT #1, "CLEAR"                    ' Send DCL.
PRINT #1, "OUTPUT 16::SYST:PRES;*CLS" ' Initialize 2002.
PRINT #1, "OUTPUT 16;*ESE 1;*SRE 32" ' Enable OPC and SRQ
PRINT #1, "OUTPUT 4;*RST;*CLS"       ' Reset 5700A calibrator.
PRINT #1, "OUTPUT 4;CUR_POST NORMAL" ' Normal current output.
C$ = ":CAL:PROT:"                    ' 2002 partial command header.
'
CLS                                    ' Clear CRT.
PRINT "Model 2002 Multimeter Comprehensive Calibration Program"
PRINT "This program controls the Fluke 5700A Calibrator."
GOSUB CheckSwitch
GOSUB KeyCheck
PRINT #1, "OUTPUT 16::CAL:PROT:INIT"  ' Initiate calibration.
RESTORE CmdList
'
FOR I = 1 TO 16                        ' Loop for all cal points.
READ Msg$, Cmd$                       ' Read message, cal strings.
SELECT CASE I ' Select cal sequence.
CASE 1, 15
PRINT #1, "OUTPUT 4;STBY"
PRINT Msg$
GOSUB KeyCheck
CASE 2
PRINT "Connect calibrator to INPUT and SENSE jacks."
PRINT "Wait 3 minutes."
GOSUB KeyCheck
PRINT #1, "OUTPUT 4;EXTSENSE OFF"
PRINT #1, "OUTPUT 4;"; Msg$
PRINT #1, "OUTPUT 4;OPER"
CASE 3, 11 TO 14
PRINT #1, "OUTPUT 4;"; Msg$
CASE 4 TO 9
PRINT #1, "OUTPUT 4;"; Msg$
PRINT #1, "OUTPUT 4;EXTSENSE ON"
PRINT #1, "OUTPUT 4;OPER"
PRINT #1, "OUTPUT 4;OUT?"
```

```

        PRINT #1, "ENTER 4"
        INPUT #2, R, R$, S
        Cmd$ = Cmd$ + " " + STR$(R)
CASE 10
        PRINT #1, "OUTPUT 4;STBY"
        PRINT "Connect calibrator to AMPS and INPUT LO jacks."
        GOSUB KeyCheck
        PRINT #1, "OUTPUT 4;"; Msg$
        PRINT #1, "OUTPUT 4;OPER"
CASE 16
        C$ = ":CAL:"
        PRINT Msg$
END SELECT
IF I <> 1 AND I <> 15 AND I <> 16 THEN GOSUB Settle
PRINT #1, "OUTPUT 16;"; C$; Cmd$; ";*OPC" ' Send cal command to 2002.
GOSUB CalEnd ' Wait until cal step ends.
GOSUB ErrCheck ' Check for cal error.
NEXT I
'
LINE INPUT "Enter calibration date (yyyy,mm,dd): "; D$
PRINT #1, "OUTPUT 16;:CAL:PROT:DATE "; D$
GOSUB ErrCheck
LINE INPUT "Enter calibration due date (yyyy,mm,dd): "; D$
PRINT #1, "OUTPUT 16;:CAL:PROT:NDUE "; D$
GOSUB ErrCheck
PRINT #1, "OUTPUT 16;:CAL:PROT:SAVE" ' Save calibration constants.
GOSUB ErrCheck
PRINT #1, "OUTPUT 16;:CAL:PROT:LOCK" ' Lock out calibration.
PRINT #1, "OUTPUT 16;:SYST:PRES" ' Restore bench defaults.
PRINT "Calibration completed."
END
'
KeyCheck: ' Check for key press routine.
WHILE INKEY$ <> "": WEND ' Flush keyboard buffer.
PRINT : PRINT "Press any key to continue (ESC to abort program)."
DO: I$ = INKEY$: LOOP WHILE I$ = ""
IF I$ = CHR$(27) THEN GOTO EndProg ' Abort if ESC is pressed.
RETURN
'
CalEnd: ' Check for cal step completion.
PRINT "Performing calibration step #"; I
DO: PRINT #1, "SRQ?" ' Request SRQ status.
INPUT #2, S ' Input SRQ status byte.
LOOP UNTIL S ' Wait for operation complete.
PRINT #1, "OUTPUT 16;*ESR?" ' Clear OPC.
PRINT #1, "ENTER 16"
INPUT #2, S
PRINT #1, "SPOLL 16" ' Clear SRQ.
INPUT #2, S
RETURN
'
ErrCheck: ' Error check routine.
PRINT #1, "OUTPUT 16;:SYST:ERR?" ' Query error queue.
PRINT #1, "ENTER 16"
INPUT #2, E, Err$
IF E <> 0 THEN BEEP: PRINT : PRINT Err$ ' Display error.
RETURN
'
CheckSwitch: ' Check CAL switch status.
PRINT #1, "OUTPUT 16;:CAL:PROT:SWIT?"
PRINT #1, "ENTER 16"
INPUT #2, S
IF S = 1 THEN RETURN
PRINT "Press CAL switch to unlock calibration."
BEEP: PRINT #1, "LOCAL 16"
GOSUB KeyCheck
GOTO CheckSwitch
'

```

```

Settle:                                     ' Calibrator settling routine.
DO: PRINT #1, "OUTPUT 4;ISR?"              ' Query status register.
PRINT #1, "ENTER 4"
INPUT #2, S
LOOP UNTIL (S AND &H1000)                  ' Test settle bit.
RETURN
'
EndProg:                                     ' Close files, end program.
BEEP: PRINT "Calibration aborted."
PRINT #1, "OUTPUT 4;STBY"
PRINT #1, "OUTPUT 16;SYST:PRES"
PRINT #1, "LOCAL 4 16"
CLOSE
END
'
CmdList:
DATA "Connect low-thermal short to inputs, wait 3 minutes.,""DC:ZERO"
DATA "OUT 2 V","DC:V2 2"
DATA "OUT 20 V","DC:V20 20"
DATA "OUT 1 MOHM","DC:OHM1M"
DATA "OUT 100 KOHM","DC:OHM200K"
DATA "OUT 19 KOHM","DC:OHM20K"
DATA "OUT 1.9 KOHM","DC:OHM2K"
DATA "OUT 190 OHM","DC:OHM200"
DATA "OUT 19 OHM","DC:OHM20"
DATA "OUT 200 UA","DC:A200U 200E-6"
DATA "OUT 2 MA","DC:A2M 2E-3"
DATA "OUT 20 MA","DC:A20M 20E-3"
DATA "OUT 200 MA","DC:A200M 200E-3"
DATA "OUT 1A","DC:A2 1"
DATA "Disconnect calibrator from INPUT and SENSE jacks.,""DC:OPEN"
DATA "Performing AC calibration, please wait...","UNPR:ACC"

```

Program B-2 Comprehensive Calibration Program for Use with Fluke 5700A Calibrator (C Version)

```

/* Model 2002 comprehensive calibration program for use with the
Fluke 5700A calibrator. Rev. 1.2. 4/7/94 */

#include <stdio.h>
#include <stdlib.h>
#include <conio.h>

FILE *ieeein,*ieeeout;

main()
{
    static char *msg[] = {
        "Connect low-thermal short, wait 3 minutes",
        "out 2 v","out 20 v","out 1 mohm","out 100 kohm",
        "out 19kohm","out 1.9 kohm","out 190 ohm",
        "out 19 ohm","out 200 ua","out 2 ma","out 20 ma",
        "out 200 ma","out 1a",
        "Disconnect calibrator from INPUT jacks",
        "Performing AC calibration, please wait..."
    };
    static char *cmd[] = {
        ":cal:prot:dc:zero",":cal:prot:dc:v2 2",
        ":cal:prot:dc:v20 20",":cal:prot:dc:ohmlm ",
        ":cal:prot:dc:ohm200k ",":cal:prot:dc:ohm20k ",
        ":cal:prot:dc:ohm2k ",":cal:prot:dc:ohm200 ",
        ":cal:prot:dc:ohm20 ",":cal:prot:dc:a200u 200e-6",
        ":cal:prot:dc:a2m 2e-3",":cal:prot:dc:a20m 20e-3",
        ":cal:prot:dc:a200m 200e-3",":cal:prot:dc:a2 1",
        ":cal:prot:dc:open",":cal:unpr:acc"
    };
    void keypress(),errcheck(),chkswit(),settle(),endpgm();
    char buf [100],date[10];
    int i,j,calend();

    if ((ieeein=fopen("IEEE","r"))==NULL) { /* Open input file. */
        printf("Cannot open IEEE-488 bus I/O.\n");
        exit(1);
    }
    ieeeeout=fopen("IEEE","w"); /* Open output file. */
    setbuf(ieeein,NULL); /* Turn off input buffering. */
    setbuf(ieeeout,NULL); /* Turn off output buffering. */
    fprintf(ieeeout,"interm crlf\n"); /* Set input terminator. */
    fprintf(ieeeout,"outterm lf\n"); /* Set output terminator. */
    fprintf(ieeeout,"remote 4 16\n"); /* Put 2002,5700A in remote. */
    fprintf(ieeeout,"clear\n"); /* Send DCL. */
    fprintf(ieeeout,"output 16::syst:pres;*cls\n"); /* Initialize 2002.*/
    fprintf(ieeeout,"output 16;*ese 1;*sre 32\n"); /* Enable OPC, SRQ.*/
    fprintf(ieeeout,"output 4;*rst;*cls\n"); /* Reset 5700A. */
    fprintf(ieeeout,"output 4;cur_post normal\n"); /* Current output */
    clrscr(); /* Clear CRT. */

    printf("Model 2002 Comprehensive Calibration Program.\n");
    printf("This program controls the 5700A Calibrator.\n");
    chkswit(); /* Check cal switch. */
    fprintf(ieeeout,"output 16;cal:prot:init\n");
    for(i=0;i<=15;i++) { /* Loop for cal points. */
        switch(i) {
            case 0: printf("%s\n",msg[i]);
                    keypress();
                    break;
            case 1: printf("Connect calibrator to 2002.\n"
                        "Wait 3 minutes.\n");
                    keypress();
                    fprintf(ieeeout,"output 4;extsense off\n");

```

```

        fprintf(ieeeeout,"output 4;%s\n",msg[i]);
        fprintf(ieeeeout,"output 4;oper\n");
        break;
    case 2: fprintf (ieeeeout,"output 4;%s\n",msg[i]);
        break;
    case 3:
    case 4:
    case 5:
    case 6:
    case 7:
    case 8: fprintf(ieeeeout,"output 4;%s\n",msg[i]);
        fprintf(ieeeeout,"output 4;extsense on\n");
        fprintf(ieeeeout,"output 4;oper\n");
        fprintf(ieeeeout,"output 4;out?\n");
        fprintf(ieeeeout,"enter 4\n");
        fgets(buf,100,ieeeein);
        j=0;
        while (buf[j++] !=',' );
        buf[--j]='\0';
        break;
    case 9: fprintf(ieeeeout,"output 4;stby\n");
        printf("Connect calibrator to AMPS and "
        "INPUT LO jacks.\n");
        keypress();
        fprintf(ieeeeout,"output 4;%s\n",msg[i]);
        fprintf(ieeeeout,"output 4;oper\n");
        break;
    case 10:
    case 11:
    case 12:
    case 13: fprintf(ieeeeout,"output 4;%s\n",msg[i]);
        break;
    case 14: fprintf(ieeeeout,"output 4;stby\n");
        printf("%s\n",msg[i]);
        keypress();
        break;
    case 15: printf("%s\n",msg[i]);
        break;
    }
    if (i!=0 && i!=14 && i!=15) settle();
    if (i>2 && i<9)
        fprintf(ieeeeout,"output 16;%s;%s;*opc\n",cmd[i],buf);
    else fprintf(ieeeeout,"output 16;%s;*opc\n",cmd[i]);
    calend(i);
    errcheck();
}
printf("Enter calibration date (yyyy,mm,dd): ");
gets(date);
fprintf(ieeeeout,"output 16;:cal:prot:date %s\n",date);
errcheck();
printf("Enter calibration due date (yyyy,mm,dd): ");
gets(date);
fprintf(ieeeeout,"output 16;:cal:prot:ndue %s\n",date);
errcheck();
fprintf(ieeeeout,"output 16;:cal:prot:save\n");
errcheck();
fprintf(ieeeeout,"output 16;:cal:prot:lock\n");
printf("Calibration completed.\n");
fprintf(ieeeeout,"output 16;:syst:pres\n");
fprintf(ieeeeout,"local 4 16\n");
fclose(ieeeein);
fclose(ieeeeout);
}
void keypress() /* Wait for keypress. */
{
    printf("\nPress any key to continue (ESC to abort).\n");
    while(kbhit()==0);
    if (getch()==27) endpgm();
}

```

```

}
int calend(n) /* Check for cal end. */
int n;
{
    int stat;
    printf("Performing cal step #d.\n",n+1);
    do {
        fprintf(ieeeeout,"srq?\n");
        fscanf(ieeeein,"%d",&stat);
    }
    while (stat==0);
    fprintf(ieeeeout,"output 16;*esr?\n");
    fprintf(ieeeeout,"enter 16\n");
    fscanf(ieeeein,"%d",&stat);
    fprintf(ieeeeout,"spoll 16\n");
    fscanf(ieeeein,"%d",&stat);
}
void errcheck() /* Check for error. */
{
    char errbuf[100];
    fprintf(ieeeeout,"output 16;;syst:err?\n");
    fprintf(ieeeeout,"enter 16\n");
    fgets(errbuf,100,ieeeein);
    if (atoi(errbuf) !=0) printf("\n%s\n",errbuf);
}
void chkswit() /* Check cal switch. */
{
    int swit=0;
    while (swit==0){
        fprintf(ieeeeout,"output 16;;cal:prot:swit?\n");
        fprintf(ieeeeout,"enter 16\n");
        fscanf(ieeeein,"%d",&swit);
        if (swit==0){
            printf("Press CAL switch to "
                "unlock calibration.\n");
            fprintf(ieeeeout,"local 16\n");
            keypad();
        }
    }
}
void settle() /* Calibrator settle. */
{
    int stat;
    do {
        fprintf(ieeeeout,"output 4;isr?\n");
        fprintf(ieeeeout,"enter 4\n");
        fscanf(ieeeein,"%d",&stat);
    }
    while (!(stat & 0x1000));
}
void endpgm() /* End program. */
{
    fprintf(ieeeeout,"output 4;stby\n");
    fprintf(ieeeeout,"output 16;;syst:pres\n");
    fprintf(ieeeeout,"local 4 16\n");
    printf("Calibration aborted.\n");
    exit(1);
}

```

Program B-3**Low-level Calibration Program for Use with Fluke 5700A Calibrator (BASIC Version)**

```

' Model 2002 low-level calibration program for use only with the
' Fluke 5700A calibrator.
' Rev. 1.2, 4/7/94
OPEN "IEEE" FOR OUTPUT AS #1          ' Open IEEE-488 output path.
OPEN "IEEE" FOR INPUT AS #2          ' Open IEEE-488 input path.
PRINT #1, "INTERM CRLF"              ' Set input terminator.
PRINT #1, "OUTTERM LF"               ' Set output terminator.
PRINT #1, "REMOTE 4 16"              ' Put 2002,5700A in remote.
PRINT #1, "CLEAR"                    ' Send DCL.
PRINT #1, "OUTPUT 16::SYST:PRES;*CLS" ' Initialize 2002.
PRINT #1, "OUTPUT 16;*ESE 1;*SRE 32" ' Enable OPC and SRQ
PRINT #1, "OUTPUT 4;*RST;*CLS"       ' Reset 5700A calibrator.
PRINT #1, "OUTPUT 4;CUR_POST NORMAL" ' Normal current output.
C$ = ":CAL:PROT:"                    ' 2002 partial command header.
'
CLS ' Clear CRT.
PRINT "Model 2002 Multimeter Low-level Calibration Program."
PRINT "This program controls the Fluke 5700A Calibrator."
GOSUB CheckSwitch
GOSUB KeyCheck
RESTORE CmdList
PRINT #1, "OUTPUT 16::CAL:PROT:INIT" ' Initiate calibration.
'
FOR I = 1 TO 29                       ' Loop for all cal points.
READ Msg$, Cmd$                       ' Read message, cal strings.
IF I = 17 THEN C$ = ":CAL:PROT:"
SELECT CASE I                          ' Select cal sequence.
CASE 1, 15, 29
PRINT #1, "OUTPUT 4;STBY"
PRINT Msg$
GOSUB KeyCheck
CASE 2, 17
PRINT "Connect calibrator to INPUT and SENSE jacks."
IF I = 2 THEN PRINT "Wait three minutes."
GOSUB KeyCheck
PRINT #1, "OUTPUT 4;EXTSENSE OFF"
PRINT #1, "OUTPUT 4;"; Msg$
PRINT #1, "OUTPUT 4;OPER"
CASE 3, 11 TO 14, 18 TO 26
PRINT #1, "OUTPUT 4;"; Msg$
PRINT #1, "OUTPUT 4;OPER"
CASE 4 TO 9
PRINT #1, "OUTPUT 4;"; Msg$
PRINT #1, "OUTPUT 4;EXTSENSE ON"
PRINT #1, "OUTPUT 4;OPER"
PRINT #1, "OUTPUT 4;OUT?"
PRINT #1, "ENTER 4"
INPUT #2, R, R$, S
Cmd$ = Cmd$ + " " + STR$(R)
CASE 10, 28
PRINT #1, "OUTPUT 4;STBY"
PRINT "Connect calibrator to AMPS and INPUT LO jacks."
IF I = 28 THEN PRINT "Select FRONT INPUT jacks."
GOSUB KeyCheck
PRINT #1, "OUTPUT 4;"; Msg$
PRINT #1, "OUTPUT 4;OPER"
CASE 16
C$ = ":CAL:"
PRINT Msg$
CASE 27
PRINT Msg$
PRINT "Select REAR INPUTS with FRONT/REAR switch."
PRINT "Wait 3 minutes for thermal equilibrium."
GOSUB KeyCheck
END SELECT

```

Calibration Programs

```
IF I <> 1 AND I <> 15 AND I <> 16 AND I <> 27 AND I <> 29 THEN GOSUB Settle
PRINT #1, "OUTPUT 16;"; C$; Cmd$; ";*OPC" ' Send cal command to 2002.
GOSUB CalEnd ' Wait until cal step ends.
GOSUB ErrCheck ' Check for cal error.
NEXT I
'
LINE INPUT "Enter calibration date (yyyy,mm,dd): "; D$
PRINT #1, "OUTPUT 16;:CAL:PROT:DATE "; D$
GOSUB ErrCheck
LINE INPUT "Enter calibration due date (yyyy,mm,dd): "; D$
PRINT #1, "OUTPUT 16;:CAL:PROT:NDUE "; D$
GOSUB ErrCheck
PRINT #1, "OUTPUT 16;:CAL:PROT:SAVE" ' Save calibration constants.
GOSUB ErrCheck
PRINT #1, "OUTPUT 16;:CAL:PROT:LOCK" ' Lock out calibration.
PRINT #1, "OUTPUT 16;:SYST:PRES" ' Restore bench defaults.
PRINT "Calibration completed."
END
'
KeyCheck: ' Check for key press routine.
WHILE INKEY$ <> "": WEND ' Flush keyboard buffer.
PRINT : PRINT "Press any key to continue (ESC to abort program)."
```

```
DO: I$ = INKEY$: LOOP WHILE I$ = ""
IF I$ = CHR$(27) THEN GOTO EndProg ' Abort if ESC is pressed.
RETURN
'
CalEnd: ' Check for cal step completion.
PRINT "Performing calibration step #"; I
DO: PRINT #1, "SRQ?" ' Request SRQ status.
INPUT #2, S ' Input SRQ status byte.
LOOP UNTIL S ' Loop until operation complete.
PRINT #1, "OUTPUT 16;*ESR?" ' Clear OPC.
PRINT #1, "ENTER 16"
INPUT #2, S
PRINT #1, "SPOLL 16" ' Clear SRQ.
INPUT #2, S
RETURN
'
ErrCheck: ' Error check routine.
PRINT #1, "OUTPUT 16;:SYST:ERR?" ' Query error queue.
PRINT #1, "ENTER 16"
INPUT #2, E, Err$
IF E <> 0 THEN BEEP: PRINT : PRINT Err$ ' Display error.
RETURN
'
CheckSwitch: ' Check CAL switch status.
PRINT #1, "OUTPUT 16;:CAL:PROT:LLEV:SWIT?"
PRINT #1, "ENTER 16"
INPUT #2, S
IF S = 1 THEN RETURN
PRINT "Calibration is locked. To unlock calibration, hold in CAL"
PRINT "switch while turning on power, then restart program."
END
'
Settle: ' Calibrator settling routine.
DO: PRINT #1, "OUTPUT 4;ISR?" ' Query status register.
PRINT #1, "ENTER 4"
INPUT #2, S
LOOP UNTIL (S AND &H1000) ' Test settle bit.
RETURN
'
EndProg:
BEEP: PRINT "Calibration aborted."
PRINT #1, "OUTPUT 4;STBY"
PRINT #1, "OUTPUT 16;:SYST:PRES"
PRINT #1, "LOCAL 4 16"
CLOSE
END
```

CmdList:

```
DATA "Connect low-thermal short to inputs, wait 3 minutes.", "DC:ZERO"
DATA "OUT 2 V", "DC:V2 2"
DATA "OUT 20 V", "DC:V20 20"
DATA "OUT 1 MOHM", "DC:OHM1M"
DATA "OUT 100 KOHM", "DC:OHM200K"
DATA "OUT 19 KOHM", "DC:OHM20K"
DATA "OUT 1.9 KOHM", "DC:OHM2K"
DATA "OUT 190 OHM", "DC:OHM200"
DATA "OUT 19 OHM", "DC:OHM20"
DATA "OUT 200 UA", "DC:A200U 200E-6"
DATA "OUT 2 MA", "DC:A2M 2E-3"
DATA "OUT 20 MA", "DC:A20M 20E-3"
DATA "OUT 200 MA", "DC:A200M 200E-3"
DATA "OUT 1A", "DC:A2 1"
DATA "Disconnect calibrator from INPUT and SENSE jacks.", "DC:OPEN"
DATA "Performing AC calibration, please wait...", "UNPR:ACC"
DATA "OUT 20 V,1 KHZ", "LLEV:STEP 1"
DATA "OUT 20 V,30 KHZ", "LLEV:STEP 2"
DATA "OUT 200 V,1 KHZ", "LLEV:STEP 3"
DATA "OUT 200 V,30 KHZ", "LLEV:STEP 4"
DATA "OUT 1.5 V,1KHZ", "LLEV:STEP 5"
DATA "OUT 0.2 V,1 KHZ", "LLEV:STEP 6"
DATA "OUT 5 MV,100KHZ", "LLEV:STEP 7"
DATA "OUT 0.5 MV,1 KHZ", "LLEV:STEP 8"
DATA "OUT 100 V,0 HZ", "LLEV:STEP 9"
DATA "OUT -20 V,0 HZ", "LLEV:STEP 10"
DATA "Connect low-thermal short to rear panel INPUT jacks.", "LLEV:STEP 11"
DATA "OUT 20 MA,1 KHZ", "LLEV:STEP 12"
DATA "Apply 2V rms @ 1Hz from synthesizer to INPUT jacks", "LLEV:STEP 13"
```

Program B-4 Low-level Calibration Program for Use with Fluke 5700A Calibrator (C Version)

```

/* Model 2002 low-level calibration program for use with the
Fluke 5700A calibrator. Rev. 1.2, 4/7/94 */

#include <stdio.h>
#include <stdlib.h>
#include <conio.h>

FILE *ieeeein,*ieeeeout;

main()
{
    static char *msg[] = {
        "Connect low-thermal short, wait 3 minutes",
        "out 2 v","out 20 v","out 1 kohm","out 100 kohm",
        "out 19kohm","out 1.9 kohm","out 190 ohm",
        "out 19 ohm","out 200 ua","out 2 ma","out 20 ma",
        "out 200 ma","out 1a",
        "Disconnect calibrator from INPUT jacks",
        "Performing AC calibration, please wait...",
        "out 20 v,1 khz","out 20 v,30 khz","out 200 v,1 khz",
        "out 200 v,30 khz","out 1.5v,1 khz","out 0.2 v,1 khz",
        "out 5 mv,100 khz","out 0.5 mv,1 khz","out 100 v,0 hz",
        "out -20v,0 hz",
        "Connect low-thermal short to rear INPUT jacks.",
        "out 20 ma,1 khz",
        "Apply 2V rms @ 1Hz from synthesizer to INPUT jacks."
    };
    static char *cmd[] = {
        ":cal:prot:dc:zero",":cal:prot:dc:v2 2",
        ":cal:prot:dc:v20 20",":cal:prot:dc:ohmlm ",
        ":cal:prot:dc:ohm200k ",":cal:prot:dc:ohm20k ",
        ":cal:prot:dc:ohm2k ",":cal:prot:dc:ohm200 ",
        ":cal:prot:dc:ohm20 ",":cal:prot:dc:a200u 200e-6",
        ":cal:prot:dc:a2m 2e-3",":cal:prot:dc:a20m 20e-3",
        ":cal:prot:dc:a200m 200e-3",":cal:prot:dc:a2 1",
        ":cal:prot:dc:open",":cal:unpr:acc",
        ":cal:prot:llev:step 1",":cal:prot:llev:step 2",
        ":cal:prot:llev:step 3",":cal:prot:llev:step 4",
        ":cal:prot:llev:step 5",":cal:prot:llev:step 6",
        ":cal:prot:llev:step 7",":cal:prot:llev:step 8",
        ":cal:prot:llev:step 9",":cal:prot:llev:step 10",
        ":cal:prot:llev:step 11",":cal:prot:llev:step 12",
        ":cal:prot:llev:step 13"
    };

    void keypress(),errcheck(),chkswit(),settle(),endpgm();
    char buf [100],date[10];
    int i,j,calend();

    if ((ieeeein=fopen("IEEE","r"))==NULL) { /* Open input file. */
        printf("Cannot open IEEE-488 bus I/O.\n");
        exit(1);
    }
    ieeeout=fopen("IEEE","w"); /* Open output file. */
    setbuf(ieeeein,NULL); /* Turn off input buffering. */
    setbuf(ieeeeout,NULL); /* Turn off output buffering. */
    fprintf(ieeeeout,"interm crlf\n"); /* Set input terminator. */
    fprintf(ieeeeout,"outterm lf\n"); /* Set output terminator. */
    fprintf(ieeeeout,"remote 4 16\n"); /* Put 2002,5700A in remote. */
    fprintf(ieeeeout,"clear\n"); /* Send DCL. */
    fprintf(ieeeeout,"output 16;syst:pres;*cls\n"); /* Initialize 2002.*/
    fprintf(ieeeeout,"output 16;*ese 1;*sre 32\n"); /* Enable OPC, SRQ.*/
    fprintf(ieeeeout,"output 4;*rst;*cls\n"); /* Reset 5700A. */
    fprintf(ieeeeout,"output 4;cur_post normal\n"); /* Normal current. */

```

```

clrscr(); /* Clear CRT. */
printf("Model 2002 Calibration Program.\n");
printf("This program controls the 5700A Calibrator.\n");
chkswit(); /* Check cal switch. */
fprintf(ieeeeout,"output 16;cal:prot:init\n");
for(i=0;i<=28;i++) { /* Loop for cal points. */
    switch(i) {
    case 0:
    case 14:
    case 28:fprintf(ieeeeout,"output 4;stby\n");
        printf("%s\n",msg[i]);
        keypress();
        break;
    case 1:
    case 16:printf("Connect calibrator to INPUT jacks.\n");
    if (i==1) printf("Wait 3 minutes.\n");
        keypress();
        fprintf(ieeeeout,"output 4;extsense off\n");
        fprintf(ieeeeout,"output 4;%s\n",msg[i]);
        fprintf(ieeeeout,"output 4;oper\n");
        break;
    case 2:
    case 10:
    case 11:
    case 12:
    case 13:
    case 17:
    case 18:
    case 19:
    case 20:
    case 21:
    case 22:
    case 23:
    case 24:
    case 25:fprintf(ieeeeout,"output 4;%s\n",msg[i]);
        fprintf(ieeeeout,"output 4;oper\n");
        break;
    case 3:
    case 4:
    case 5:
    case 6:
    case 7:
    case 8: fprintf(ieeeeout,"output 4;%s\n",msg[i]);
        fprintf(ieeeeout,"output 4;oper\n");
        fprintf(ieeeeout,"output 4;extsense on\n");
        fprintf(ieeeeout,"output 4;out?\n");
        fprintf(ieeeeout,"enter 4\n");
        fgets(buf,100,ieeeein);
        j=0;
        while (buf[j++]!='\n');
        buf[--j]='\0';
        break;
    case 9:
    case 27:fprintf(ieeeeout,"output 4;stby\n");
        printf("Connect calibrator to AMPS and "
            "INPUT LO jacks.\n");
        if (i==27) printf("Select FRONT INPUTS\n");
        keypress();
        fprintf(ieeeeout,"output 4;%s\n",msg[i]);
        fprintf(ieeeeout,"output 4;oper\n");
        break;
    case 15:printf("%s\n",msg[i]);
        break;
    case 26:printf("%s\n",msg[i]);
        printf("Select REAR INPUT jacks with "
            "FRONT/REAR switch.\n"
            "Wait 3 minutes for thermal "
            "equilibrium\n");

```

```

        keypress();
        break;
    }
    if (i!=0 && i!=14 && i!=15 && i!=26 && i!=28) settle();
    if (i>2 && i<9)
        fprintf(ieeeeout,"output 16;:s;s;*opc\n",cmd[i],buf);
    else fprintf(ieeeeout,"output 16;:s;*opc\n",cmd[i]);
    calend(i);
    errcheck();
}
printf("Enter calibration date (yyyy,mm,dd): ");
gets(date);
fprintf(ieeeeout,"output 16;:cal:prot:date %s\n",date);
errcheck();
printf("Enter calibration due date (yyyy,mm,dd): ");
gets(date);
fprintf(ieeeeout,"output 16;:cal:prot:ndue %s\n",date);
errcheck();
fprintf(ieeeeout,"output 16;:cal:prot:save\n");
errcheck();
fprintf(ieeeeout,"output 16;:cal:prot:lock\n");
fprintf(ieeeeout,"output 16;:syst:pres\n");
fprintf(ieeeeout,"local 4 16\n");
printf("Calibration completed.\n");
fclose(ieeeein);
fclose(ieeeeout);
}
void keypress() /* Wait for keypress. */
{
    printf("\nPress any key to continue (ESC to abort).\n");
    while(kbhit()==0);
    if (getch()==27) endpgm();
}
int calend(n) /* Check for cal end. */
int n;
{
    int stat;
    printf("Performing calibration step #%d.\n",n+1);
    do {
        fprintf(ieeeeout,"srq?\n");
        fscanf(ieeeein,"%d",&stat);
    }
    while (stat==0);
    fprintf(ieeeeout,"output 16;*esr?\n");
    fprintf(ieeeeout,"enter 16\n");
    fscanf(ieeeein,"%d",&stat);
    fprintf(ieeeeout,"spoll 16\n");
    fscanf(ieeeein,"%d",&stat);
}
void errcheck() /* Check for error. */
{
    char errbuf[100];
    fprintf(ieeeeout,"output 16;:syst:err?\n");
    fprintf(ieeeeout,"enter 16\n");
    fgets(errbuf,100,ieeeein);
    if (atoi(errbuf) !=0) printf("\n%s\n",errbuf);
}
void chkswit() /* Check cal switch. */
{
    int swit;
    fprintf(ieeeeout,"output 16;:cal:prot:llev:swit?\n");
    fprintf(ieeeeout,"enter 16\n");
    fscanf(ieeeein,"%d",&swit);
    if (swit==0){
        printf("Calibration is locked.\n"
            "To unlock, hold in CAL while turning on "
            "power, then restart program.\n");
        exit (1);
    }
}

```

```
    }  
}  
void settle() /* Calibrator settle. */  
{  
    int stat;  
    do {  
        fprintf(ieeeout,"output 4;isr?\n");  
        fprintf(ieeeout,"enter 4\n");  
        fscanf(ieeein,"%d",&stat);  
    }  
    while (!(stat & 0x1000));  
}  
void endpgm() /* End program. */  
{  
    fprintf(ieeeout,"output 4;stby\n");  
    printf("Calibration aborted.\n");  
    fprintf(ieeeout,"local 4 16\n");  
    exit(1);  
}
```

C

Calibration Messages

C.1 Introduction

This appendix lists calibration errors that may occur during calibration as well as the :CAL:PROT:DATA? query response.

C.2 Error summary

Table C-1 summarizes Model 2002 calibration errors. These errors are displayed on the front panel and may be read over the bus by using the :SYST:ERR? query. The query response is the error number and the error message enclosed in quotes. For example,

```
+444,"Cal step generated invalid data"
```

Error generation

After each calibration command is sent, the Model 2002 will perform the appropriate calibration step and calculate pertinent calibration constants. If an error is detected, the instrument will generate the appropriate error message, as summarized in Table C-1.

Temperature drift error

An "Excessive temp drift during cal" error (+519) may occur if the internal temperature of the Model 2002 drifts excessively during calibration. The Model 2002 measures its internal temperature when the ":CAL:PROT:INIT" command is sent and then again when the ":CAL:PROT:SAVE" command is sent at the end of the calibration procedure. If the internal temperature drift is excessive, the ERR annunciator

will turn on, and the "Excessive temp drift during cal" message will be placed in the error queue.

Note that this error condition does not prevent calibration constants derived during calibration from being saved; rather, it is intended to flag excessive temperature drift, possibly caused by insufficient warm-up.

NOTE

Placement of the OPTION SLOT cover affects the internal temperature of the Model 2002. To achieve $T_{CAL} \pm 1^{\circ}C$ specifications, the OPTION SLOT cover must be in the same position (on or off) as when the Model 2002 is to be used.

Invalid calibration data error

A "Cal step generated invalid data" error (+444) will be generated when the ":CAL:PROT:SAVE" command is executed if a previous calibration step failed. This error will be repeated for each ":CAL:PROT:SAVE" command until the calibration step in question is successfully completed.

C.3 Calibration data query response

Table C-2 lists the response to the :CAL:PROT:DATA? query. The response is a string of ASCII floating-point numbers separated by commas, and it is not affected by the FORMAT command. Constants listed in Table C-2 are shown in the order they are sent.

Table C-1
Calibration error messages

Error number	Message
+350	“200µa zero out of spec”
+351	“2ma zero out of spec”
+352	“20ma zero out of spec”
+353	“200ma zero out of spec”
+354	“2a zero out of spec”
+355	“Divz x50 zero out of spec”
+356	“1000v zero out of spec”
+357	“200v zero out of spec”
+358	“20v zero out of spec”
+359	“10v zero out of spec”
+360	“2v zero out of spec”
+361	“200mv zero out of spec”
+362	“1M ohm 4wz out of spec”
+363	“1M ohm 2wz out of spec”
+364	“200k ohm 4wz out of spec”
+365	“200k ohm 2wz out of spec”
+366	“20k ohm 4wz out of spec”
+367	“20k ohm 2wz out of spec”
+368	“2k ohm 4wz out of spec”
+369	“2k ohm 2wz out of spec”
+370	“OC 4w x5 zero out of spec”
+371	“OC 2w x5 zero out of spec”
+372	“200 ohm 4wz out of spec”
+373	“200 ohm 2wz out of spec”
+374	“20 ohm 4wz out of spec”
+375	“20 ohm 2wz out of spec”
+376	“OC 4w x50 zero out of spec”
+377	“OC 2w x50 zero out of spec”
+378	“2v full scale out of spec”
+379	“7v reference out of spec”
+380	“20v full scale out of spec”
+381	“20v div x5 out of spec”
+382	“20v div x50 out of spec”
+383	“Hi ohms res out of spec”
+384	“1M ohm fs out of spec”
+385	“200k ohm fs out of spec”
+387	“20k ohm fs out of spec”
+388	“20k ohm fs oc out of spec”
+389	“2k ohm fs out of spec”

Table C-1 (cont.)
Calibration error messages

Error number	Message
+390	“2k ohm fs oc out of spec”
+391	“200 ohm fs out of spec”
+392	“200 ohm fs oc out of spec”
+393	“20 ohm fs out of spec”
+394	“20 ohm fs oc out of spec”
+395	“200ua full scale out of spec”
+396	“2ma full scale out of spec”
+397	“20ma full scale out of spec”
+398	“200ma full scale out of spec”
+399	“2A full scale out of spec”
+400	“Hi ohms voltage out of spec”
+405	“x1 rms gain out of spec”
+406	“x1 rms offset out of spec”
+407	“x10 rms gain out of spec”
+408	“x10 rms offset out of spec”
+409	“x1 fwr gain out of spec”
+410	“x1 fwr offset out of spec”
+411	“x10 fwr gain out of spec”
+412	“x10 fwr offset out of spec”
+413	“d100 atten out of spec”
+414	“d500 atten out of spec”
+415	“Pos x10 peak offset out of spec”
+416	“Neg x10 peak offset out of spec”
+417	“x1 peak offset out of spec”
+418	“Pos 20V peak offset out of spec”
+419	“Neg 20V peak offset out of spec”
+420	“d100 self cal DAC out of spec”
+421	“d500 self cal DAC out of spec”
+422	“acvalhigh out of spec”
+423	“dcvalhigh out of spec”
+424	“tmpdiv100 out of spec”
+425	“divval2 out of spec”
+426	“divval3 out of spec”
+427	“tmpdiv200 out of spec”
+428	“tmpdiv500 out of spec”
+429	“acvallow out of spec”
+430	“dcvallow out of spec”
+431	“lowrngcorr out of spec”
+432	“maxdacfrwd1 out of spec”
+433	“maxdacbkwd1 out of spec”
+434	“vavgnoise10 out of spec”
+435	“dcdivcal out of spec”
+436	“d100 div cal did not converge”
+437	“d500 div cal did not converge”
+438	“rollm200mv out of spec”
+439	“rear short circuit out of spec”

Table C-1 (cont.)

Calibration error messages

Error number	Message
+440	“ampsac out of spec”
+441	“ampsacdc out of spec”
+442	“lfac out of spec”
+443	“lfacdc out of spec”
+444	“Cal step generated invalid data”
+445	“Preamp 1k gain out of spec”
+446	“Preamp 10k gain out of spec”
+447	“Preamp 100k gain out of spec”
+510	“Reading buffer data lost”
+511	“GPIB address lost”
+512	“Power-on state lost”
+513	“AC calibration data lost”
+514	“DC calibration data lost”
+515	“Calibration dates lost”
+516	“Installed option id lost”
+517	“Preamp calibration data lost”
+518	“Low level calibration data lost”
+519	“Excessive temp drift during cal”
+610	“Questionable Calibration”
+611	“Questionable Temperature”
+900	“Internal System Error”

Note: Bus response to :SYST:ERR? query includes error number, comma, and error message surrounded by double quotes.

Table C-2
Calibration constants returned by :CAL:PROT:DATA? query

Cal constant	Description
g1	RMS gain for 2V, 200V, and 750V ranges
of1	RMS offset for 2V, 200V, and 750V AC ranges
g10	RMS gain for 200mV and 20V AC ranges
of10	RMS offset for 200mV and 20V AC ranges
gfwr1	Average gain for 2V, 200V, and 750V AC ranges
offwr1	Average offset for 2V, 200V, and 750V AC ranges
gfwr10	Average gain for 200mV and 20V AC ranges
offwr10	Average offset for 200mV and 20V AC ranges
a100	100:1 divider attenuation factor
a500	500:1 divider attenuation factor
ofpkpos10	Positive peak offset for 200mV AC range
ofpkneg10	Negative peak offset for 200mV AC range
ofpk1	Positive and negative peak offset for 2V, 200V, and 750V AC ranges
ofpkpos20	Positive peak offset for 20V AC range
ofpkneg20	Negative peak offset for 20V AC range
div100self	Self-calibration code for frequency compensation DAC, 100:1 divider
div500self	Self-calibration code for frequency compensation DAC, 500:1 divider
c200uaz	200 μ A zero
c2maz	2mA zero
c20maz	20mA zero
c200maz	200mA zero
c2az	2A zero
cdivzx50	x50 divider zero
c1000vz	1000V zero
c200vz	200V zero
c20vz	20V zero
c10vz	10V zero
c2vz	2V zero
c200mvz	200mV zero
c1mr4wz	1M Ω 4-wire zero
c1mrz	1M Ω 2-wire zero
c200kr4wz	200k Ω 4-wire zero
c200krz	200k Ω 2-wire zero
c20kr4wz	20k Ω 4-wire zero
c20kr4wzon	20k Ω 4-wire zero OC on
c20kr4wzoff	20k Ω 4-wire zero OC off
c20krz	20k Ω 2-wire zero
c20krzon	20k Ω 2-wire zero OC on
c20krzoff	20k Ω 2-wire zero OC off
c2kr4wz	2k Ω 4-wire zero
c2kr4wzon	2k Ω 4-wire zero OC on
c2kr4wzoff	2k Ω 4-wire zero OC off
c2krz	2k Ω 2-wire zero
c2krzon	2k Ω 2-wire zero OC on
c2krzoff	2k Ω 2-wire zero OC off
c200r4wz	200 Ω 4-wire zero
c200r4wzon	200 Ω 4-wire zero OC on
c200r4wzoff	200 Ω 4-wire zero OC off
c200rz	200 Ω 2-wire zero

Table C-2 (cont.)

Calibration constants returned by :CAL:PROT:DATA? query

Cal constant	Description
c200rzon	200 Ω 2-wire zero OC on
c200rzoff	200 Ω 2-wire zero OC off
c20r4wz	20 Ω 4-wire zero
c20r4wzon	20 Ω 4-wire zero OC on
c20r4wzoff	20 Ω 4-wire zero OC off
c20rz	20 Ω 2-wire zero
c20rzon	20 Ω 2-wire zero OC on
c20rzoff	20 Ω 2-wire zero OC off
c2vfs	2V full scale
c7vref	7V reference
c20vfs	20V full scale
c20vfsdivx5	20V full scale divider x5
c20vfsdivx50	20V full scale divider x50
chiohmres	Hi ohms resistance
c1mrfs	1M Ω full scale
c200krfs	200k Ω full scale
c20krfs	20k Ω full scale
c20krfson	20k Ω full scale OC on
c20krfsoff	20k Ω full scale OC off
c2krfs	2k Ω full scale
c2krfson	2k Ω full scale OC on
c2krfsoff	2k Ω full scale OC off
c200rfs	200 Ω full scale
c200rfson	200 Ω full scale OC on
c200rfsoff	200 Ω full scale OC off
c20rfs	20 Ω full scale
c20rfson	20 Ω full scale OC on
c20rfsoff	20 Ω full scale OC off
c200uafs	200 μ A full scale
c2mafs	2mA full scale
c20mafs	20mA full scale
c200mafs	200mA full scale
c2afs	2A full scale
chiohmvolt	Hi ohms voltage
usr2v	2V cal point
usr20v	20V cal point
usr1mr	1M Ω cal point
usr200kr	200k Ω cal point
usr20kr	20k Ω cal point
usr2kr	2k Ω cal point
usr200r	200 Ω cal point
usr20r	20 Ω cal point
usr200ua	200 μ A cal point
usr2ma	2mA cal point
usr20ma	20mA cal point
usr200ma	200mA cal point
usr2a	2A cal point
inttemp	Calibration temperature
acvalhigh	AC-coupled cal value for low ranges
dcvalhigh	AC-coupled cal value for high ranges

Table C-2 (cont.)

Calibration constants returned by :CAL:PROT:DATA? query

Cal constant	Description
tmpdiv100	/100 divider cal value
divval2	Divider cal value 2
divval3	Divider cal value 3
tmpdiv200	/200 divider cal value
tmpdiv500	/500 divider cal value
acvallow	AC-coupled cal value for low ranges
dcvallow	DC-coupled cal value for low ranges
lowrngcorr	Correction factor for low ranges
maxdacfrwd1	Forward hysteresis DAC value
maxdacbkwd1	Backward hysteresis DAC value
vavgnoise10	x10 average noise factor
dcdivcal	DC attenuator correction
rollm200mv	Negative full-scale rollover value
c20vz	Rear 20V zero
c2vz	Rear 2V zero
c200mvz	Rear 200mV zero
c1mr4wz	Rear 1M Ω 4-wire zero
c1mrz	Rear 1M Ω 2-wire zero
c200kr4wz	Rear 200k Ω 4-wire zero
c200krz	Rear 200k Ω 2-wire zero
c20kr4wz	Rear 20k Ω 4-wire zero
c20krz	Rear 20k Ω 2-wire zero
c2kr4wz	Rear 2k Ω 4-wire zero
c2krz	Rear 2k Ω 2-wire zero
c200r4wz	Rear 200 Ω 4-wire zero
c200rz	Rear 200 Ω 2-wire zero
c20r4wz	Rear 20 Ω 4-wire zero
c20rz	Rear 20 Ω 2-wire zero
ampsac	AC-coupled amps cal value
ampsacdc	DC-coupled amps cal value
lfac	AC-coupled LFRMS cal value
lfacdc	DC-coupled LFRMS cal value

NOTE: Constants are returned as an ASCII string of floating-point numbers separated by commas. Constants are sent in the order shown, and entire string is terminated by a newline (<LF> + EOI).

D

Calibration Command Summary

Table D-1
Calibration commands

Command	Description
:CALibration	Calibration root command.
:PROTeCted	All commands in this subsystem are protected by the CAL switch (except queries).
:INITiate	Initiate calibration.
:LOCK	Lock out calibration (opposite of enabling cal with CAL switch).
:SWITCh?	Request comprehensive CAL switch state. (0 = locked; 1 = unlocked)
:SAVE	Save cal constants to EEROM.
:DATA?	Download cal constants from 2002.
:DATE <yr>, <mon>, <day>	Send cal date to 2002.
:DATE?	Request cal date from 2002.
:NDUE <yr>, <mon>, <day>	Send next due cal date to 2002.
:NDUE?	Request next due cal date from 2002.
:DC	Comprehensive calibration subsystem.
:ZERO	Short-circuit calibration step.
:V2 <NRf>	+2V DC calibration step.
:V20 <NRf>	+20V DC calibration step.
:OHM1M <NRf>	1M Ω calibration step.
:OHM200K <NRf>	200k Ω calibration step.
:OHM20K <NRf>	20k Ω calibration step.
:OHM2K <NRf>	2k Ω calibration step.
:OHM200 <NRf>	200 Ω calibration step.
:OHM20 <NRf>	20 Ω calibration step.
:A200U <NRf>	200 μ A DC calibration step.
:A2M <NRf>	2mA DC calibration step.
:A20M <NRf>	20mA DC calibration step.
:A200M <NRf>	200mA DC calibration step.
:A2 <NRf>	2A DC calibration step.
:OPEN	Open-circuit calibration step.

Table D-1
Calibration commands

Command	Description
:LLEVEl	Low-level calibration subsystem.
:SWITCh?	Request low-level CAL switch state. (0 = locked; 1 = unlocked)
:STEP <Step #>	
1	20V AC at 1kHz step.
2	20V AC at 30kHz step.
3	200V AC at 1kHz step.
4	200V AC at 30kHz
5	1.5V AC at 1kHz step.
6	200mV AC at 1kHz step.
7	5mV AC at 100kHz step.
8	0.5mV AC at 1kHz step.
9	+100V DC step.
10	-20V DC step.
11	Rear inputs short-circuit step.
12	20mA AC at 1kHz step.
13	2V AC at 1Hz step.
:UNPRotected	Commands in this subsystem not protected by CAL switch.
:ACCompensation	Perform user AC calibration (disconnect all cables)

NOTE: Upper-case letters indicate short form of each command. For example, instead of sending ":CALibration:PROTEcted:INITiate", you can send ":CAL:PROT:INIT".

Symbols

:ACCompensation 3-13
:CALibration:PROTEcted subsystem 3-3
:CALibration:UNPRotected subsystem 3-13
:DATA? 3-5
:DATE 3-5
:DC 3-6
:INIT 3-3
:LLEVel 3-11
:LOCK 3-3
:NDUE 3-5
:SAVE 3-4
:SWITCH 3-4

Numerics

1G Ω range verification 1-15
20M Ω and 200M Ω range verification 1-14
20 Ω -2M range verification 1-13

A

AC current verification 1-12
AC peak mode 1-10
AC self-calibration 2-12
AC volts verification 1-6
Additional derating factors 1-2

B

BASIC program requirements B-1
Bus error reporting 3-13

C

Calibration 2-1
Calibration command reference 3-1
Calibration command summary D-1
Calibration data query response C-1
Calibration equipment B-1

Calibration error summary 3-13
Calibration errors 2-4
Calibration lock 2-2
Calibration messages C-1
Calibration programs B-1
Command summary 3-1
Commands 3-1
Comprehensive calibration 2-4, B-3
Comprehensive calibration lock 2-2
Computer hardware requirements B-1

D

DC current verification 1-11
DC volts verification 1-4
Detecting calibration errors 3-13
Detecting calibration step completion 3-14

E

Environmental conditions 1-1, 2-2
Error generation C-1
Error summary C-1
Error queue 3-13

F

Frequency accuracy verification 1-15
Front panel AC calibration 2-12
Front panel comprehensive calibration 2-4
Front panel error reporting 2-4
Front panel low-level calibration procedure 2-16
Front panel single-point calibration 2-24

G

General program instructions B-3
Generating an SRQ on calibration complete 3-14
Generating an SRQ on error 3-13

I

IEEE-488 bus AC self-calibration 2-13
IEEE-488 bus calibration commands 2-2
IEEE-488 bus calibration lock status 2-2
IEEE-488 bus comprehensive calibration 2-9
IEEE-488 bus error reporting 2-4
IEEE-488 bus low-level calibration procedure 2-20
IEEE-488 bus single-point calibration 2-24
Introduction 1-1, 2-1, 3-1, B-1, C-1
Invalid calibration data error C-1

L

Line power 1-2, 2-2
Low-frequency mode 1-9
Low-level calibration 2-13, B-3
Low-level calibration lock 2-2
Low-level calibration summary 2-13

N

Normal mode 1-6

P

Performance verification 1-1

R

Recommended equipment for comprehensive calibration 2-4
Recommended equipment for low-level calibration 2-13
Recommended test equipment 1-2
Reading limit calculation example 1-2
Resistance verification 1-13
Restoring default conditions 1-2
RTD temperature reading checks 1-18

S

Selecting the temperature sensor 1-17
Single-point calibration 2-24
Specifications A-1
Status byte EAV (Error Available) Bit 3-13

T

Temperature drift error C-1
Temperature reading checks 1-17
Thermocouple temperature reading
checks 1-17
Turbo C program requirements B-1

U

Unlocking calibration B-3
Using the *OPC command 3-14
Using the *OPC query 3-14

V

Verification limits 1-2
Verification procedures 1-4

W

Warm-up period 1-1, 2-2



Service Form

Model No. _____ Serial No. _____ Date _____

Name and Telephone No. _____

Company _____

List all control settings, describe problem and check boxes that apply to problem. _____

- | | | |
|--------------------------------------------------|----------------------------------------------------------|--------------------------------------------------------------------------|
| <input type="checkbox"/> Intermittent | <input type="checkbox"/> Analog output follows display | <input type="checkbox"/> Particular range or function bad; specify _____ |
| <input type="checkbox"/> IEEE failure | <input type="checkbox"/> Obvious problem on power-up | <input type="checkbox"/> Batteries and fuses are OK |
| <input type="checkbox"/> Front panel operational | <input type="checkbox"/> All ranges or functions are bad | <input type="checkbox"/> Checked all cables |

Display or output (check one)

- | | |
|-----------------------------------|------------------------------------------------------|
| <input type="checkbox"/> Drifts | <input type="checkbox"/> Unable to zero |
| <input type="checkbox"/> Unstable | <input type="checkbox"/> Will not read applied input |
| <input type="checkbox"/> Overload | |

- | | |
|-------------------------------------------|--------------------------------------------------------------|
| <input type="checkbox"/> Calibration only | <input type="checkbox"/> Certificate of calibration required |
| <input type="checkbox"/> Data required | |

(attach any additional sheets as necessary)

Show a block diagram of your measurement system including all instruments connected (whether power is turned on or not). Also, describe signal source.

Where is the measurement being performed? (factory, controlled laboratory, out-of-doors, etc.)

What power line voltage is used? _____ Ambient temperature? _____ °F

Relative humidity? _____ Other? _____

Any additional information. (If special modifications have been made by the user, please describe.)

Be sure to include your name and phone number on this service form.

Specifications are subject to change without notice.

All Keithley trademarks and trade names are the property of Keithley Instruments, Inc. All other trademarks and trade names are the property of their respective companies.



Keithley Instruments, Inc.

BELGIUM: Keithley Instruments B.V.
CHINA: Keithley Instruments China
FRANCE: Keithley Instruments Sarl
GERMANY: Keithley Instruments GmbH
GREAT BRITAIN: Keithley Instruments Ltd.
INDIA: Keithley Instruments GmbH
ITALY: Keithley Instruments s.r.l.
KOREA: Keithley Instruments Korea
NETHERLANDS: Keithley Instruments B.V.
SWITZERLAND: Keithley Instruments SA
TAIWAN: Keithley Instruments Taiwan

28775 Aurora Road • Cleveland, Ohio 44139 • 440-248-0400 • Fax: 440-248-6168
1-888-KEITHLEY (534-8453) www.keithley.com

Bergensesteenweg 709 • B-1600 Sint-Pieters-Leeuw • 02/363 00 40 • Fax: 02/363 00 64
Yuan Chen Xin Building, Room 705 • 12 Yumin Road, Dewai, Madian • Beijing 100029 • 8610-6202-2886 • Fax: 8610-6202-2892
3, allée des Garays • 91127 Palaiseau Cédex • 01 64 53 20 20 • Fax: 01 60 11 77 26
Landsberger Strasse 65 • D-82110 Germering • 089/84 93 07-40 • Fax: 089/84 93 07-34
The Minster • 58 Portman Road • Reading, Berkshire RG30 1EA • 0118-9 57 56 66 • Fax: 0118-9 59 64 69
Flat 2B, WILLOCRISSA • 14, Rest House Crescent • Bangalore 560 001 • 91-80-509-1320/21 • Fax: 91-80-509-1322
Viale San Gimignano, 38 • 20146 Milano • 02-48 39 16 01 • Fax: 02-48 30 22 74
2FL., URI Building • 2-14 Yangjae-Dong • Seocho-Gu, Seoul 137-130 • 82-2-574-7778 • Fax: 82-2-574-7838
Postbus 559 • NL-4200 AN Gorinchem • 0183-635333 • Fax: 0183-630821
Kriesbachstrasse 4 • 8600 Dübendorf • 01-821 94 44 • Fax: 01-820 30 81
1FL., 85 Po Ai Street • Hsinchu, Taiwan, R.O.C. • 886-3-572-9077 • Fax: 886-3-572-9031